

# KEYNOTES

- ① Concrete Substrate
- ② Epoxy Primer
- ③ Broadcast Coat
- ④ Polyaspartic Topcoats
- ⑤ WB Flat Polyurethane Sealer

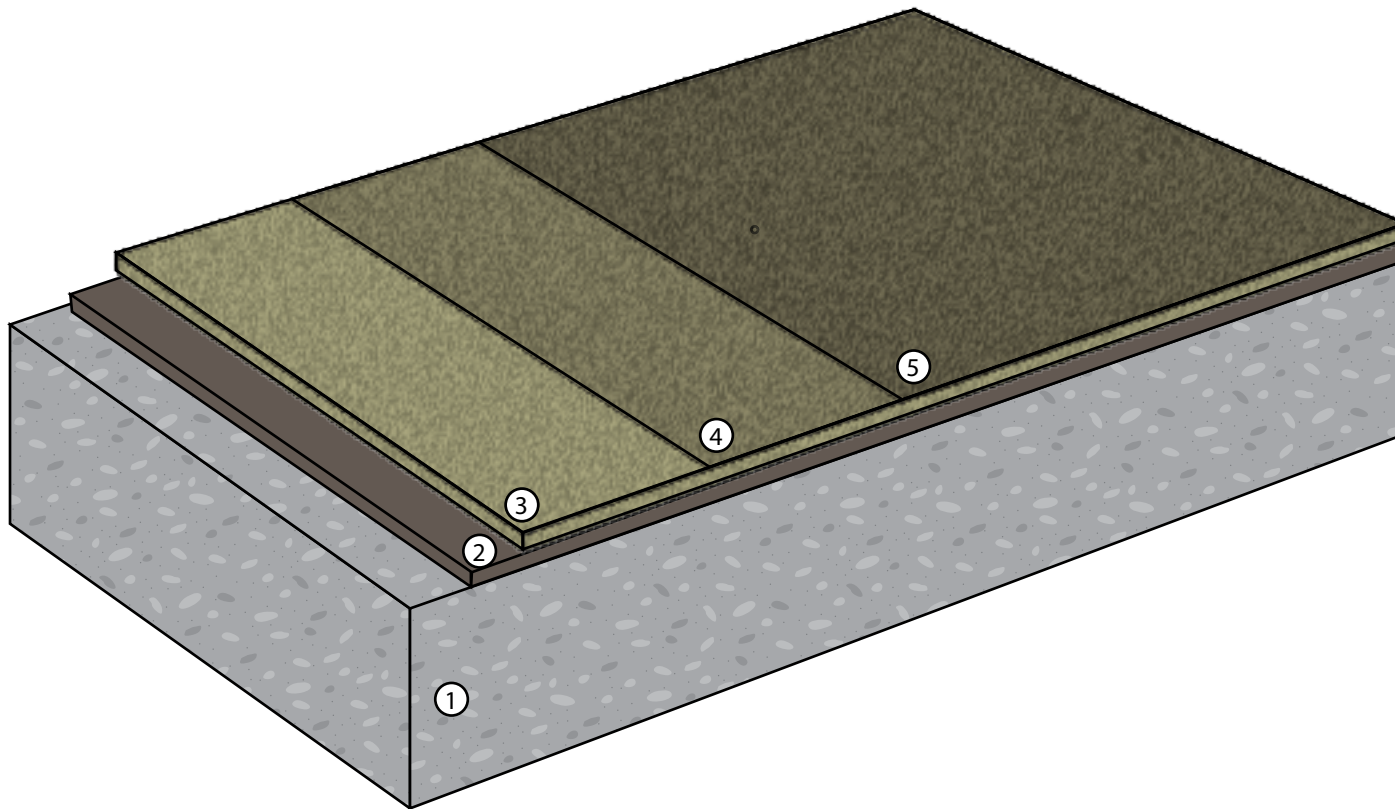

- Concrete must be a minimum 2,500 PSI.
- Concrete must be cured for a minimum 28 days.
- Concrete should be prepared to a profile equal to ICRI CSP 3.
- Refer to local building codes and standards.
- Refer to all Product and System Specifications for additional information.

REV. 2/16/23

## TIDALSTONE FLOORING SYSTEM - THIN FILM - SYSTEM OVERVIEW

DIVISION 09 67 23  
Fluid-Applied Flooring

SCALE : NTS



**westcoat**  
SPECIALTY COATING SYSTEMS

4007 Lockridge Street • San Diego, CA • 92102  
800.250.4519 • westcoat.com