

KEYNOTES

- ① Concrete Substrate
- ② Temper-Crete Coat
(EC-24 & TC-24)

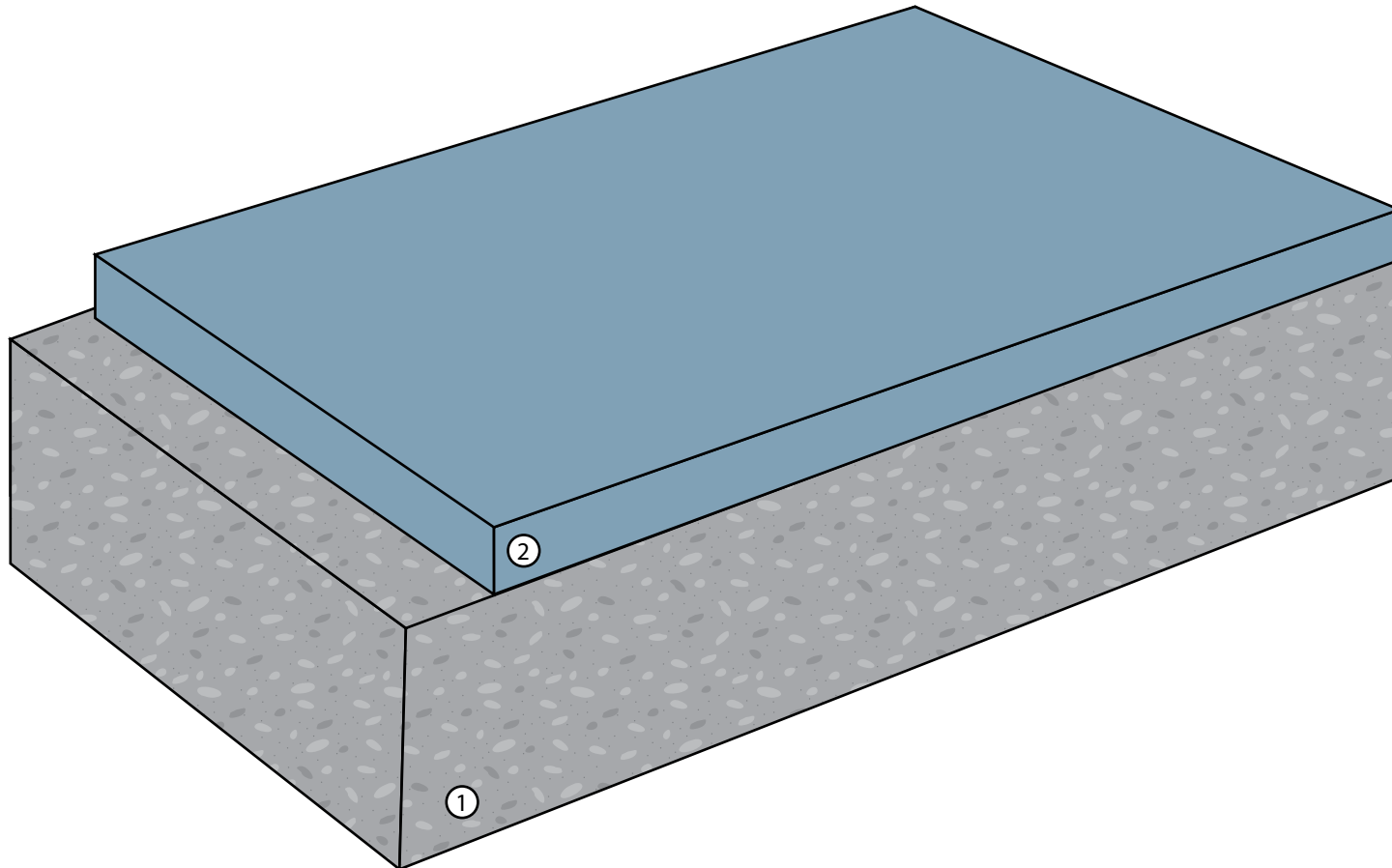

- Optional Primer Coat may be installed as needed.
- Concrete must be a minimum 3,500 PSI.
- Concrete must be cured for a minimum 14 days.
- Concrete should be prepared to a profile equal to ICRI CSP 3-5.
- Refer to local building codes and standards.
- Refer to all Product and System Specifications for additional information.

REV.6-2-22 TC

TEMPER-CRETE SL - SYSTEM OVERVIEW

DIVISION 09 67 23
Resinous Flooring

SCALE : NTS



westcoat
SPECIALTY COATING SYSTEMS

4007 Lockridge Street • San Diego, CA • 92102
800.250.4519 • westcoat.com