

WESTCOAT MACOAT OUTSIDE CORNER FLASHING DECK TERMINATION DETAIL (OVER CONCRETE)

NOT TO SCALE

NOTES:

- APPLY WP-51 ON ALL FLASHING SEAMS AND OVERLAPS. STANDARD OVERLAP IS BOTTOM TO TOP WITH A 4" OVERLAP.
- 2500 PSI MINIMUM FOR CONCRETE SUBSTRATES
- $\frac{5}{8}$ " EXTERIOR GRADE MINIMUM FOR PLYWOOD SUBSTRATE
- $\frac{1}{4}$ " MINIMUM SLOPE REQUIRED ON ALL DECKS
- REFER TO LOCAL BUILDING CODES & STANDARDS

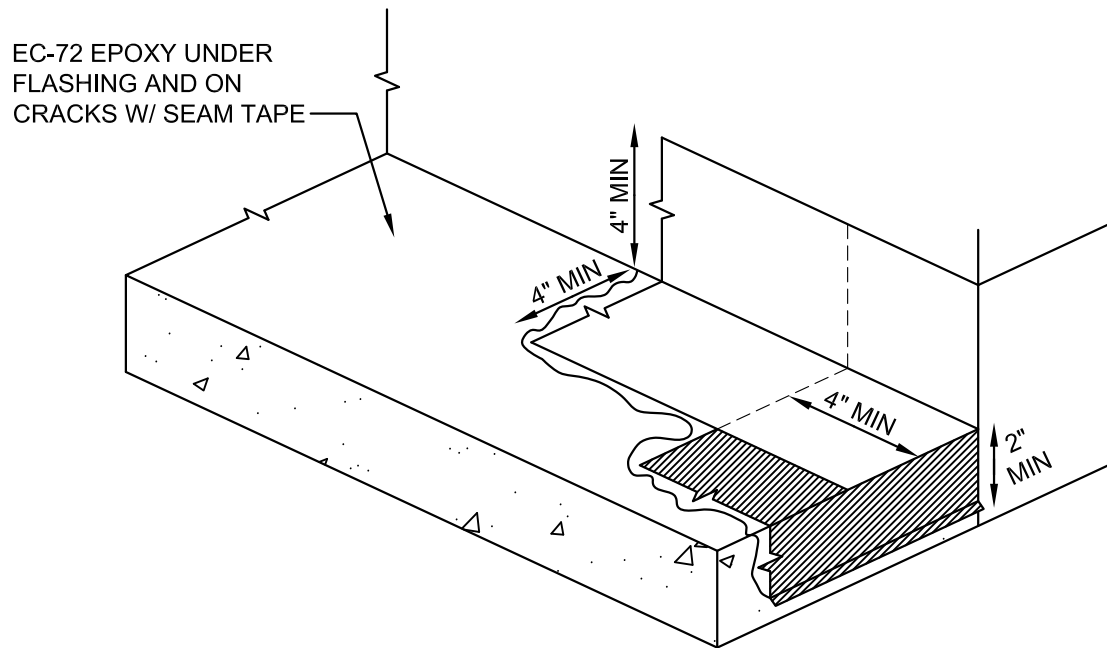

FIRST PIECE

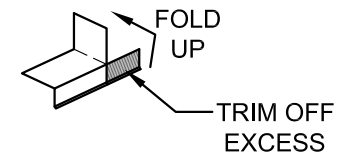
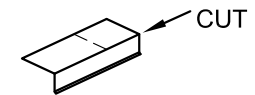

SECOND PIECE

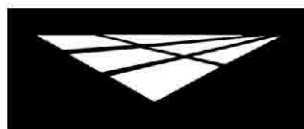
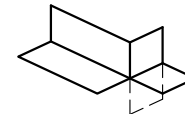
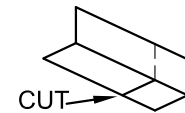

westcoat

800-250-4519
770 GATEWAY CENTER DRIVE

www.westcoat.com
SAN DIEGO, CA. 92102