

## WESTCOAT MACOAT DECK EDGE & WALL-TO-DECK DETAIL (OVER CONCRETE)

NOT TO SCALE

### NOTES:

- APPLY WP-51 ON ALL FLASHING SEAMS AND OVERLAPS. STANDARD OVERLAP IS BOTTOM TO TOP WITH A 4" OVERLAP.
- 2500 PSI MINIMUM FOR CONCRETE SUBSTRATES
- $\frac{5}{8}$ " EXTERIOR GRADE MINIMUM FOR PLYWOOD SUBSTRATE
- $\frac{1}{4}$ " MINIMUM SLOPE REQUIRED ON ALL DECKS
- REFER TO LOCAL BUILDING CODES & STANDARDS

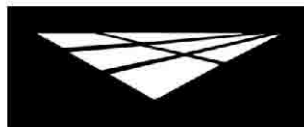
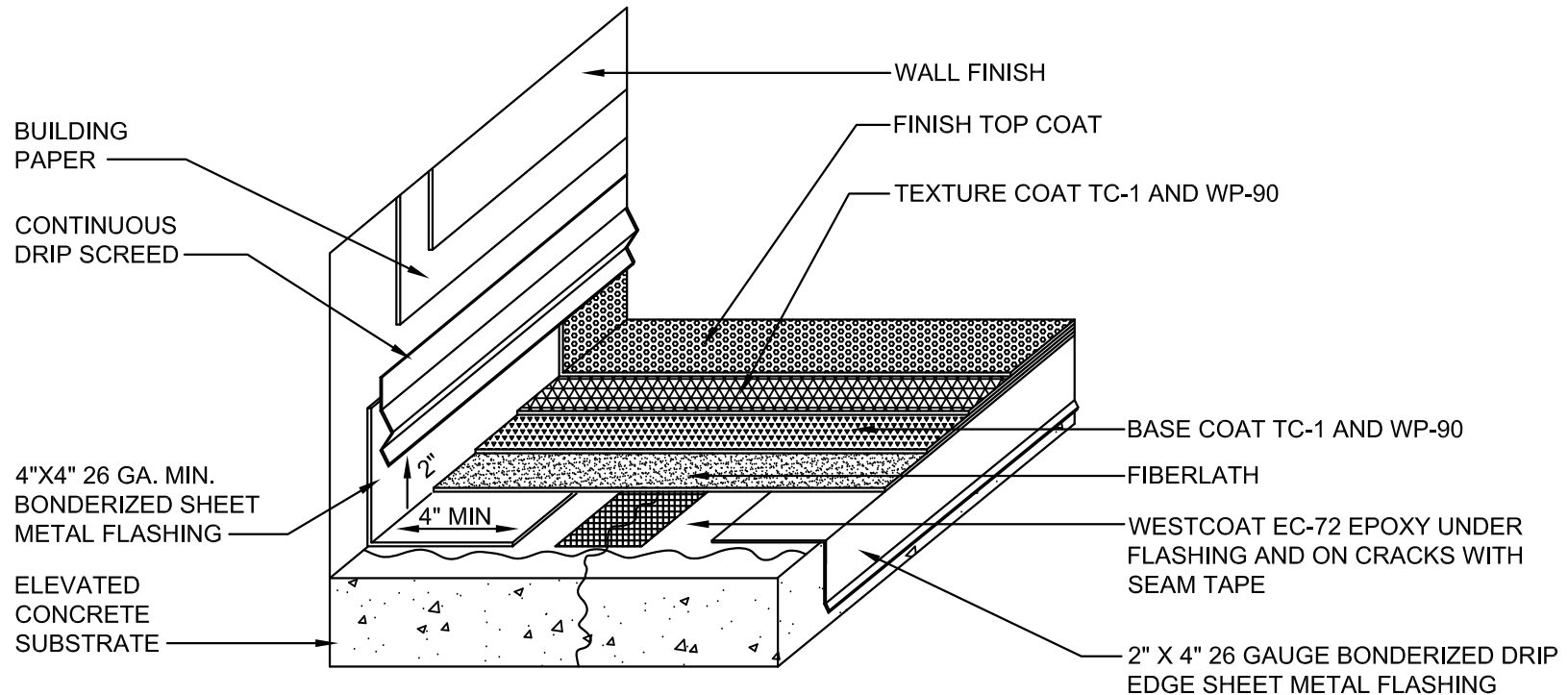

# westcoat

800-250-4519  
4007 LOCKRIDGE STREET

www.westcoat.com  
SAN DIEGO, CA. 92102