

## CRACK REPAIR: HIGH BUILD SYSTEMS

NOT TO SCALE

### NOTES:

- 2500 PSI MINIMUM CONCRETE SUBSTRATES
- SEE ICRI STANDARDS FOR PROPER CONCRETE PREP
- REFER TO LOCAL BUILDING CODES AND DEPARTMENT OF ENVIRONMENTAL HEALTH STANDARDS

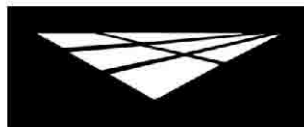
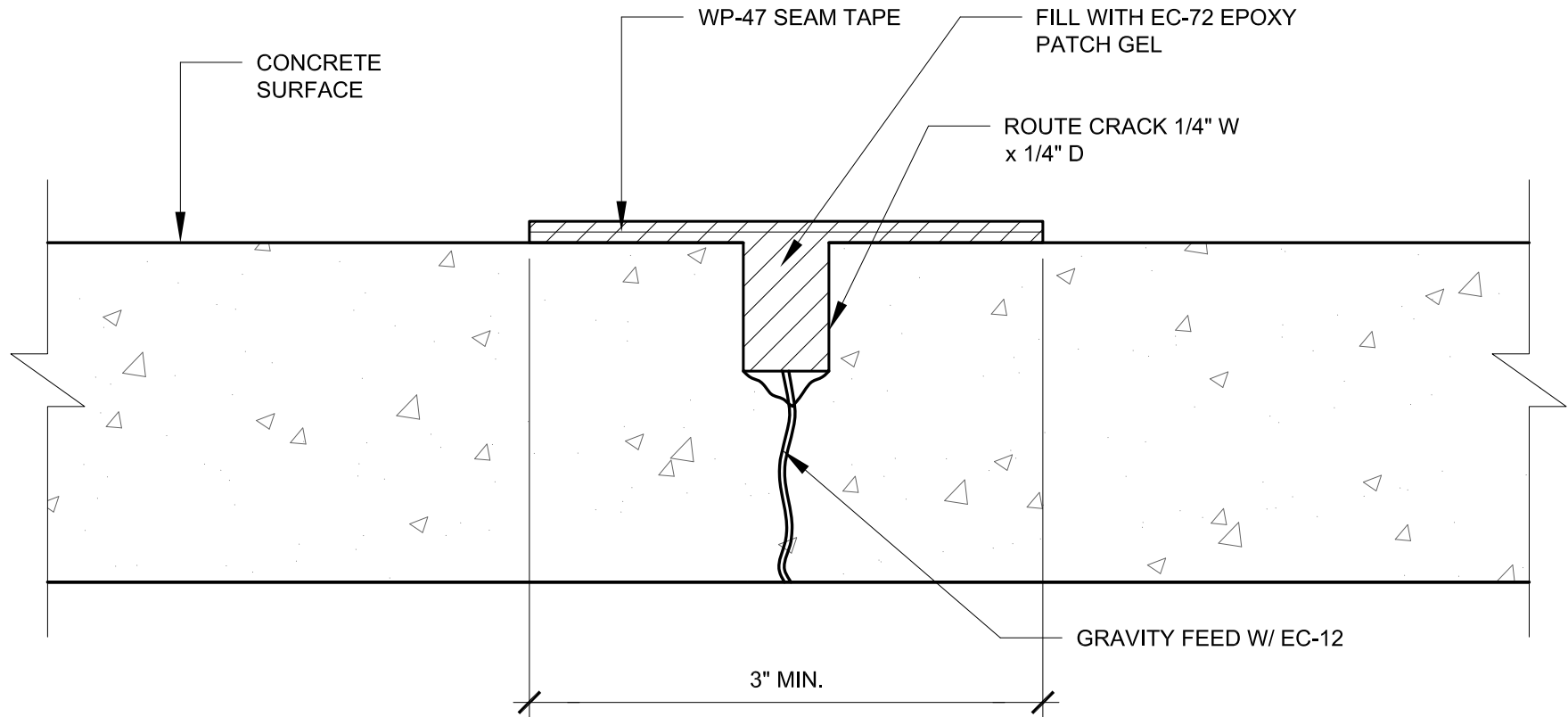

# westcoat

800-250-4519  
4007 LOCKRIDGE STREET

www.westcoat.com  
SAN DIEGO, CA. 92102