

**westcoat**<sup>®</sup>  
SPECIALTY COATING SYSTEMS

# EPOXY SLURRY



**EPOXY COAT**  
DURABLE RESINS & HARDENERS



**westcoat**®  
SPECIALTY COATING SYSTEMS

# EPOXY SLURRY SUBMITTAL PACKAGE

DIVISION 09 – FINISHES  
SECTION 09 67 23 RESINOUS FLOORING

## TABLE OF CONTENTS

---

<b>System Brochure</b>	<b>3-5</b>
<b>System Specification Sheet</b>	<b>6-11</b>
<b>CSI Specification</b>	<b>12-16</b>
<b>Color Chart</b>	<b>17-18</b>
<b>Sample Warranty</b>	<b>19-20</b>
<b>General Maintenance</b>	<b>21-23</b>
<b>Architectural Details</b>	<b>24-30</b>



**westcoat**®  
SPECIALTY COATING SYSTEMS

# SYSTEM BROCHURE



## ABOUT EPOXY SLURRY

Westcoat's Epoxy Slurry System is a multi-component, 100% solids epoxy floor coating. This epoxy system is blended with slurry filler or graded silica to provide extra strength. This powerhouse system provides a high build that is tough, chemical resistant, low odor durable and self-leveling. Epoxy Slurry is used to create seamless floors in manufacturing plants, mechanical rooms, warehouses, commercial kitchens, restaurants, garages, and service areas.



## ULTRA-TOUGH. PROTECTIVE.

- USDA Compliant
- Chemical Resistant
- 100% Solids
- Low Odor
- High Build
- High Strength
- Self-Leveling



**FOR PROFESSIONAL USE ONLY.**





### The System

Westcoat's Epoxy Slurry is a multi-component, 100% solids epoxy floor coating system, blended with slurry filler or graded silica. Pigmented topcoat provides powerful durability and chemical resistance.

Epoxy Slurry



Concrete    Primer    Slurry Coat    Pigmented Topcoat

Epoxy Slurry is USDA and FDA compliant and can withstand daily cleaning and sanitizing without degrading the coating system. The 100% solids epoxy topcoat is available in several opaque colors including Occupational Safety and Health Administration (OSHA) safety spectrum color availabilities.

Create seamless floors in manufacturing plants, mechanical rooms, warehouses, commercial kitchens, restaurants, garages and service areas.





**westcoat**®  
SPECIALTY COATING SYSTEMS

# SYSTEM SPECIFICATION SHEET

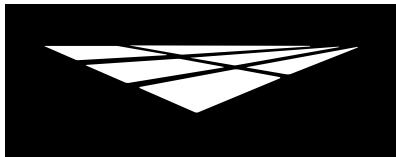

**Description**

Westcoat's Epoxy Slurry System is a multi-component, 100% solids epoxy floor coating, blended with slurry filler or graded silica. It provides a high-build system that is tough, chemical resistant, low odor and durable.

**Uses**

Epoxy Slurry is used to create seamless floors in manufacturing plants, mechanical rooms, warehouses, commercial kitchens, restaurants, garages and service areas. The Epoxy Slurry System is designed to be used as a medium duty coating.

**System Overview**

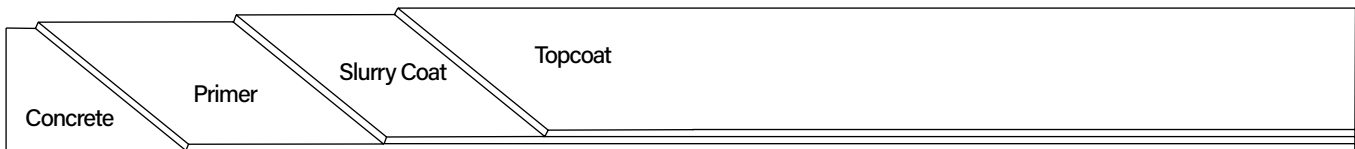

System Data			
<b>Coverages</b>	<b>Primer</b> 250-300 ft <sup>2</sup> per gallon	<b>Slurry Coat</b> 20-21 ft <sup>2</sup> per mix at 1/4" thick 40-42 ft <sup>2</sup> per mix at 1/8" thick 80-84 ft <sup>2</sup> per mix at 1/16" thick	<b>Topcoat</b> 250-300 ft <sup>2</sup> per gallon
<b>Components</b>	<a href="#">EC-72 Epoxy Patch Gel</a> <a href="#">EC-76 Cove Gel</a> <a href="#">EC-12 Epoxy Primer</a> <a href="#">EC-34 Epoxy Topcoat</a> TC-71 Slurry Filler		<b>Shelf Life</b> 2 years 2 years 2 years 2 years 2 years

**Advantages**

- USDA Compliant
- Chemical Resistant
- 100% Solids
- Low Odor
- High Build
- High Strength
- Self-Leveling

**Inspection**

The surface must be structurally sound, clean, dry and free of grease, paint, oil, dust, curing agents, laitance or any foreign material that will prevent proper adhesion. The concrete should be at least 2,500 PSI and porous or rough enough to allow the product to soak in. A minimum of 28 days curing time is required on all concrete. Prior to starting work, test existing concrete slab for efflorescence, moisture and hydrostatic pressure.

DISCLAIMER: PURCHASER'S SOLE AND EXCLUSIVE REMEDY AGAINST THE MANUFACTURER OF WESTCOAT, SHALL BE LIMITED SOLELY TO THE REPLACEMENT OF ANY DEFECTIVE MATERIAL OR A PAYMENT BY THE MANUFACTURER IN AN AMOUNT EQUAL TO THE COST OF THE ORIGINAL MATERIAL.



**westcoat**<sup>®</sup>  
SPECIALTY COATING SYSTEMS

**SYSTEM  
SPECIFICATION**

**EC**

**EPOXY COAT**  
DURABLE RESINS & HARDENERS

## Epoxy Slurry

### Preparation

Pre-cut and clean all cracks and joints with a concrete diamond blade to at least ¼ x ¼ inch. Prepare concrete to a profile equal to CSP 3-5 as specified by ICRI. Methods may vary according to the condition and hardness of the concrete. Other factors include the forecasted use of the surface and the environment in which it is to be installed. When preparing the surface use caution when shot blasting, scarifying too aggressively, leaving grind marks or grinding too smooth.

### Moisture

All concrete should be tested for moisture before applying a seamless coating. If moisture emissions exceed 5 lbs/1000 square feet (ASTM F1869) or if the relative humidity (RH) exceeds 75% (ASTM F2170), please refer to the EC-15 Moisture Vapor Barrier Product Specification Sheet.

### Crack Treatment

Mix 1 part A with 1 part B (by volume) of EC-72 Epoxy Patch Gel together for 3-4 minutes and apply to the crack using a trowel or putty knife. Patch all spalls and cracks with EC-72 and allow to dry 2-3 hours before priming. The material may be slightly overfilled in the crack and when completely dry (in 4-6 hours) can be sanded or ground smooth. If desired, use EC-76 Cove Gel to create cove at the wall to deck transition. Cove may be created using a cove tool. This remedial approach to patch cracks is not guaranteed and it should be noted that when the substrate moves, it could likely crack the Epoxy Slurry System.

### Concrete Repair

For concrete that needs repairs beyond just dormant cracks, TC-23 Mortar Mix can be used. TC-23 is designed to be used as a general concrete repair mix for horizontal and vertical applications and can be used as a patching/underlayment material under most Westcoat systems. Please refer to the TC-23 Mortar Mix Product Specification Sheet for details.

### Cove Base

Install cove cap or cut a reglet at the desired height (usually 6 inches). Mix 2 parts A with 1 part B (by volume) of EC-76 Cove Gel together for 3-4 minutes and spread as thin as possible onto the vertical surface. Immediately, using the same neat mix, combine with 5 parts TC-73 Epoxy Mortar Sand and trowel into place using an inside step tool and trowel to smooth. Lubricate the trowel using a solvenated rag, as needed, to keep tools clean.

### Primer

Mix 2 parts A with 1 part B (by volume) of EC-12 Epoxy Primer together for 3-4 minutes. For best penetration into concrete, thin by adding 1-2 quarts of Westcoat's CA-23 to each 1½ gallon kit. Thinned material must be applied at less than 5 mils. To cure properly, do not allow product to puddle. Immediately apply at a rate of 250-300 square feet per gallon, using a trowel or squeegee and then back roll to ensure complete coverage. Be sure to apply up cove to termination point.

DISCLAIMER: PURCHASER'S SOLE AND EXCLUSIVE REMEDY AGAINST THE MANUFACTURER OF WESTCOAT, SHALL BE LIMITED SOLELY TO THE REPLACEMENT OF ANY DEFECTIVE MATERIAL OR A PAYMENT BY THE MANUFACTURER IN AN AMOUNT EQUAL TO THE COST OF THE ORIGINAL MATERIAL.



**westcoat**<sup>®</sup>

4007 Lockridge St • San Diego, CA 92102  
800-250-4519 • Fax 619-255-7187 • westcoat.com

2 of 5  
Epoxy Slurry 2/23



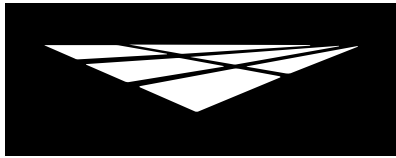

**westcoat**<sup>®</sup>  
SPECIALTY COATING SYSTEMS

**SYSTEM  
SPECIFICATION**

**EC**

**EPOXY COAT**  
DURABLE RESINS & HARDENERS

## Epoxy Slurry

### Slurry Coat

Mix a 1½ gallon batch of EC-34 with approximately 1½ gallons of TC-71 Slurry Filler, to create an epoxy slurry mix. Use a gauge rake to apply slurry mix at approximately 20-21 square feet per mix at ¼ inch thick, 40-42 square feet per mix at ⅛ inch thick and 80-84 square feet per mix at ⅙ inch thick. After gauge raking, back roll with a porcupine roller to facilitate self leveling and to reduce the possibility of bubbles. Various aggregates, quartz sand or additional silica sand can be broadcast into wet slurry coat if needed, to help build up coating, level, hide additional imperfections or to create texture. When the coating is dry, scrape, grind or sand as necessary.

### Topcoat

Mix 2 parts A and 1 part B (by volume) of EC-34 Epoxy Topcoat for 3-4 minutes. For color consistency, box all part A's. Apply at a rate of 250-300 square feet per gallon using a notched squeegee or trowel and back roll using a high quality, non-shedding ¼ inch nap roller. If additional coats are desired, they must be applied within 24 hours or the cured material must be sanded and wiped with acetone, before application.

Prohibit traffic on floor for 48 hours after installation. Avoid heavy abrasion and chemical exposure for 5 days. Allow 72 hours minimum for vehicular traffic.

### Optional Materials

#### Cement Options

- TC-23 Mortar Mix may be used as a general concrete repair mix for horizontal and vertical applications and can be used as a patching/underlayment material.

#### Skid Resistance

- CA-30 Small Safe Grip or CA-31 Large Safe Grip can be added to the EC-34 to produce a skid-resistant surface.
- CA-33 Aluminum Oxide can be used for skid resistance in heavy traffic areas.

#### Slurry Coat

- For smaller projects, EC-36 100% Solids Epoxy plus the desired CA-36 Epoxy Color Pack can be used in lieu of EC-34 for the Slurry Coat.

#### Topcoat

- For smaller projects, EC-36 100% Solids Epoxy plus the desired CA-36 Epoxy Color Pack can be used in lieu of EC-34 for the Topcoat.

#### Additional Topcoat

- EC-32 Clear Epoxy Topcoat can be used instead of EC-34 when decorative quartz sand is broadcast into the slurry coat.
- EC-95G Gloss Polyurethane Topcoat can be applied over the epoxy within 24 hours to improve chemical abrasion and UV resistance, as well as gloss.
- EC-101 Polyaspartic 100% Solids may be used as a non-yellowing, high gloss, quick drying, high build, mar and chemical resistant finish with outstanding wear resistance.
- EC-102 Polyaspartic is recommended when tire staining is a concern and also provides a quick drying, UV resistant, high gloss, high build, mar and chemical resistant finish.
- EC-50 Novolac may be used as a final topcoat for extreme chemical or heat conditions.

\* Please refer to Product and System Specification Sheets for additional information.

DISCLAIMER: PURCHASER'S SOLE AND EXCLUSIVE REMEDY AGAINST THE MANUFACTURER OF WESTCOAT, SHALL BE LIMITED SOLELY TO THE REPLACEMENT OF ANY DEFECTIVE MATERIAL OR A PAYMENT BY THE MANUFACTURER IN AN AMOUNT EQUAL TO THE COST OF THE ORIGINAL MATERIAL.



4007 Lockridge St • San Diego, CA 92102  
800-250-4519 • Fax 619-255-7187 • westcoat.com

3 of 5  
Epoxy Slurry 2/23

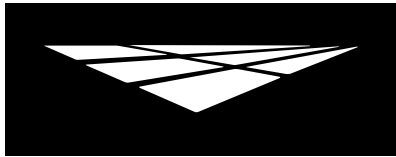

**westcoat**<sup>®</sup>  
SPECIALTY COATING SYSTEMS

**SYSTEM  
SPECIFICATION**

**EC**

**EPOXY COAT**  
DURABLE RESINS & HARDENERS

## Epoxy Slurry

### Clean Up

Uncured material can be removed with solvent. If cured, material can only be removed mechanically or with an environmentally-safe solvent.

### Maintenance

Interior Floors can be dust mopped daily or mopped using a neutral pH cleaner. For more information on floor care and maintenance, please refer to the General Maintenance sheet.

If recoating of the floor is required due to wear or abrasion, you will need to clean and degrease the surface, then lightly abrade and reapply the topcoat. In most cases you will need to clean the surface with a solvent, such as acetone and thin the new topcoat as well. A primer may be required. We suggest you recoat at 5 years, depending on use. Contact Westcoat or your applicator for details.

### Health Precautions

Inhalation of vapor or mist can cause headache, nausea, irritation of nose, throat and lungs. Avoid breathing vapors. It is strongly recommended that respirators are worn. Prolonged or repeated skin contact can cause slight skin irritation. All epoxies have the potential of causing skin irritations or allergic reactions. Be careful not to get on skin, clothes or in eyes. Gloves are strongly recommended. If splashed in the eye, flush with warm water and contact a physician if blurring persists.

Solvent based products are extremely flammable. Extinguish all pilot lights and sources of ignition, such as electrical motors. Be sure to have adequate cross ventilation prior to installing.

### Limitations

- This system is designed for professional use only.
- Read Product Specification Sheets for every product you will be using before beginning the project.
- Be sure to do adequate surface preparation.
- Be sure to measure and mix properly.
- For interior use only.
- Test for moisture in concrete and vapor drive.
- Be aware of the pot life of mixed material.
- Do not apply in temperatures below 50°F or temperatures above 95°F. Cooler temperatures will cause slower dry times.
- Heavier topcoat may become slippery.
- Approval and verification of proposed colors, textures and slip resistance is recommended.
- Do not allow Westcoat products to freeze.

### Slip Precaution

Westcoat Specialty Coatings Systems highly recommends the use of a slip-resistant additive to all coatings/systems that may be exposed to wet, oily, greasy or slippery conditions. It is the end user's responsibility to provide a flooring system that meets current safety standards. Westcoat and its distributors will not be responsible for injury incurred during a slip and fall incident. For the current coefficient of friction requirements, please consult your local building codes.

DISCLAIMER: PURCHASER'S SOLE AND EXCLUSIVE REMEDY AGAINST THE MANUFACTURER OF WESTCOAT, SHALL BE LIMITED SOLELY TO THE REPLACEMENT OF ANY DEFECTIVE MATERIAL OR A PAYMENT BY THE MANUFACTURER IN AN AMOUNT EQUAL TO THE COST OF THE ORIGINAL MATERIAL.



**westcoat**<sup>®</sup>

4007 Lockridge St • San Diego, CA 92102  
800-250-4519 • Fax 619-255-7187 • westcoat.com

4 of 5  
Epoxy Slurry 2/23



**EC**

**EPOXY COAT**  
DURABLE RESINS & HARDENERS

**Epoxy Slurry**

**Technical Data**

ASTM / Test Data	Westcoat Epoxy Slurry
Tensile Properties (ASTM D638)	Strength - Neat Epoxy 4,000 psi, Elongation - Neat Epoxy 12% (7 day cure)
Tensile Strength (ASTM C307)	>1800 Resin, Hardener
Flexural Properties (ASTM D790)	N/A - see Thin Film data
Flexural Strength (ASTM C580)	4,000 psi (+/- 200 psi)
Slant Shear Strength (ASTM C882)	N/A - see Thin Film data
Compressive Strength (ASTM C-579)	11,000 psi - 7 day cure
Hardness (Indentation - ASTM D2240)	80-85 Shore D - 14 day cure
Indentation (Load - Mil-D-3134, Para. 4.7.4.2.1)	0.005 in indentation - 7 day cure  Method: 1 in. diameter steel ram steadily applies a load of 2,000 lbs for 30 min on the test specimen that is placed on the concrete.
Indentation (Impact - Mil-D-3134, Para. 4.7.3)	0.014 indentation - 7 day cure (No chipping, cracking, loss of adhesion)  Method: 2 lb steel ball is dropped twice from an 8 ft. height
Adhesion to Concrete (Tensile Pull - ACI 503 R)	350 psi (100% concrete failure CSP 3-4)
Abrasion Resistance (Taber - ASTM D4060)	50 mg. 1000 cycles, 1000 g. load, Wheel No. 17 14 day cure
Water Absorption (ASTM C-413)	<0.2% - 7 day cure
Thermal Coefficient of Linear Expansion (ASTM C-531)	10.0 x 10 <sup>-6</sup> in. / in./°F (7 day cure)
Fungus & Bacteria Growth (Mil-F-52505, 4.4.2.11)	Will not support growth of fungus or bacteria when subjected to mildew and bacteria tests
Microbial Resistance (ASTM G21)	Pass
Thermal Shock Resistance (ASTM C-884)	Pass
LEED EQ Credit 4.1	Meets
LEED EQ Credit 4.2	Meets
Temperature Resistance	Continuous exposure: 140 °F Intermittent exposure: 200 °F
Flammability Rate of Burning (ASTM D635)	CC1 (<25mm) will not sustain a flame (free film), also will not sustain a flame over concrete
Flame Spread (ASTM E-84/NFPA 255)	Un-rated system
Critical Radiant Flux (ASTM E648)	Class I (>45 watts/cm2)

DISCLAIMER: PURCHASER'S SOLE AND EXCLUSIVE REMEDY AGAINST THE MANUFACTURER OF WESTCOAT, SHALL BE LIMITED SOLELY TO THE REPLACEMENT OF ANY DEFECTIVE MATERIAL OR A PAYMENT BY THE MANUFACTURER IN AN AMOUNT EQUAL TO THE COST OF THE ORIGINAL MATERIAL.



**westcoat**®  
SPECIALTY COATING SYSTEMS

# CSI SPECIFICATION



## SECTION 09 67 23 RESINOUS FLOORING EPOXY SLURRY SYSTEM

### PART 1 GENERAL

#### 1.01 SUMMARY

- A. Section includes: Provide a complete epoxy floor system for concrete surfaces that meet the requirements for specific use indicated in the contract documents. Include all applicable substrate testing, surface preparation, and detail work.

#### 1.02 RELATED SECTIONS

- A. Section 033000 – Cast-In-Place Concrete
- B. Section 090000 - Finishes

#### 1.03 SUBMITTALS

- A. Submit under provisions of Section 013300.
- B. Product Data: Submit manufacturer's product data sheets on each product and system to be used including:
  - 1. Preparation instructions and recommendations.
  - 2. Storage and handling requirements.
  - 3. Installation methods.
  - 4. Maintenance requirements.
- C. Selection Samples: For each system specified, provide two sets of samples and color charts, representing manufacturer's full range of colors and patterns.

#### 1.04 QUALITY ASSURANCE

- A. All materials used in the epoxy floor system shall be manufactured and provided by a single manufacturer to ensure compatibility and proper bonding.
- B. Use adequate numbers of skilled workmen thoroughly trained and experienced in the necessary crafts and completely familiar with the specified requirements and methods needed for proper performance of the work of this section.
- C. Contractor shall have a minimum of 3 years experience installing epoxy floor coatings similar to that which is required for this project and who is acceptable to the manufacturer.
  - 1. Applicator shall designate a single individual as project foreman who shall be on site at all times during installation.
  - 2. Contractor must show and have QCA Qualified Contractor/Applicator paperwork from the manufacturer of the coating system, as required to obtain a long-term jobsite specific warranty.
- D. Convene a pre-application meeting before the start of application of coating system. Require attendance of parties directly affecting work of this section, including: Architect, contractor, applicator, and authorized representative of the coating system manufacturer and interfacing trades. Review the following:
  - 1. Drawings and specifications affecting work of this section.
  - 2. Protection of adjacent surfaces.
  - 3. Surface preparation and substrate conditions.
  - 4. Application.
  - 5. Field quality control.
  - 6. Protection of coating system.
  - 7. Repair of coating system.
  - 8. Coordination with other work.

## 1.05 DELIVERY, STORAGE & HANDLING

- A. Delivery: Materials shall be delivered to the job site in sealed, undamaged containers. Each container shall be clearly marked with manufacturer's label showing type of material, color, and lot number.
- B. Storage: Store all materials in a clean, dry place with a temperature range in accordance with manufacturer's instructions.
- C. Handling: Handle products carefully to avoid damage to the containers. Read all labels and Material Safety Data Sheets prior to use.

## 1.06 PROJECT SITE CONDITIONS

- A. Maintain environmental conditions (temperature, humidity, and ventilation) within the limits recommended by the manufacturer.
- B. All concrete should be tested for moisture before applying a seamless coating. If moisture emissions exceed 5 lbs/1000 square feet (ASTM F1869) or if the relative humidity (RH) exceeds 75% (ASTM F2170), see EC-15 Moisture Vapor Barrier product specification.
- C. Concrete must be at least 2500 psi.
- D. Concrete must be cured for a minimum of 28 days before coating is applied.
- E. Schedule coating work to avoid excessive dust and airborne contaminants. Protect work areas from excessive dust and airborne contaminants during coating application.
- F. Before any work is started, the applicator shall examine all surfaces for any deficiencies. Should any deficiencies exist, the architect, owner or general contractor shall be notified in writing and any corrections necessary shall be made.

## 1.07 WARRANTY

- A. Upon completion of the work in this section provide a written warranty from the manufacturer against defects of materials for a period of 1 (one) year. To obtain project specific warranty the coating system applicator must be a Westcoat Qualified Contractor/ Applicator and apply for warranty.

## **PART 2 PRODUCTS**

### 2.01 MANUFACTURERS

- A. Acceptable manufacturer: Westcoat Specialty Coatings; 4007 Lockridge Street, San Diego, CA 92102. Telephone 800-250-4519. Fax 619-255-7187. Website: [www.westcoat.com](http://www.westcoat.com).

### 2.02 MATERIALS

- A. As basis of design Westcoat Epoxy Slurry (no substitutions will be accepted): Multi-component 100% solids epoxy floor coating, blended with slurry powder or graded silica.

### 2.03 MATERIALS

- A. Epoxy Slurry System: 100% Solids High Build Epoxy Slurry.
  - 1. Primer: EC-12 Epoxy Primer 250-300 square feet per gallon.
  - 2. Slurry Coat: 1 ½ gallons EC-34 Epoxy Topcoat mixed with 1 ½ gallons TC-71 Slurry Filler. Apply at a rate of 25-100 square feet per mix.
  - 3. Top Coat: EC-34 Epoxy Topcoat pigmented 250-300 feet per gallon.

### 2.04 ACCESSORIES

- A. Supplemental Materials:
  - 1. EC-32 Clear Epoxy Topcoat can be used instead of EC-34 when decorative quartz sand is broadcast into the slurry coat.
  - 2. Patching materials shall be EC-72 Epoxy Patch Gel.

3. Concrete repairs can be made with TC-23 Mortar Mix as needed.
4. Optional cove base shall be EC-76 Epoxy Cove Gel.
5. Optional aggregate shall be CA-30 Small Safe Grip, CA-31 Large Safe Grip or TC-70 Silica Sand designed to meet the owners skid resistance requirements.

Optional Topcoats:

6. EC-50 Novolac may be used IN LIEU of EC-34 for extreme chemical or heat conditions.
7. SC-65G WB Gloss Polyurethane may be used OVER the EC-34 when a low odor, solvent free, mar and chemical/UV resistant gloss finish is required.
8. SC-65SG Pigmented WB Semi-Gloss Polyurethane may be used OVER the EC-34 when a low odor, solvent free, mar and chemical/UV resistant semi-gloss finish is required.
9. SC-65F WB Flat Polyurethane may be used OVER the EC-34, SC-65G Gloss, or SC-65SG Semi-Gloss when a low odor, solvent free, mar and chemical/UV resistant flat finish is required.
10. EC-95G Gloss Polyurethane may be used OVER the EC-34 when a chemical/UV resistant, solvent-based gloss finish is required.
11. EC-95F Flat Polyurethane may be used OVER the EC-34 or EC-95G when a chemical/UV resistant, solvent-based flat finish is required.
12. EC-101 Polyaspartic 100% Solids may be used OVER the EC-34 as a non-yellowing, high gloss, quick drying, high build, mar and chemical resistant finish with outstanding wear resistance.
13. EC-102 Polyaspartic may be used OVER the EC-34 when tire staining is a concern. Provides a quick drying, UV resistant, high gloss, high build, mar and chemical resistant finish.

## **PART 3 EXECUTION**

### **3.01 EXAMINATION**

- A. Verification of Conditions.
  1. Inspect all surfaces to receive epoxy flooring. The surface must be structurally sound, clean, dry and free of grease, paint, oil, dust, curing agents, laitance or any foreign material that will prevent proper adhesion.
  2. Conduct calcium chloride testing according to ASTM F1869.
  3. Before starting work, report in writing to the authority having jurisdiction any unsatisfactory conditions.

### **3.02 SURFACE PREPARATION**

- A. Prepare surfaces using methods recommended by the manufacturer for achieving the best result for the substrate under the project conditions.
- B. Shot blast or mechanically abrade the surface to achieve a surface profile equal to CSP of 3-5 as specified by ICRI.
- C. Clean Surfaces thoroughly prior to installation.
- D. Rout and clean moving cracks and joints: fill with manufacturer's recommended flexible epoxy filler material.
- E. Repair any non-moving surface deviations with manufacturer's recommended patching material.

### **3.03 INSTALLATION**

- A. Install coatings in accordance with manufacturer's instructions.
- B. Mix multi-component materials in accordance with manufacturer's instructions.
- C. Use application equipment, tools, and techniques in accordance with manufacturer's instructions.
- D. Uniformly apply coatings at spread rates and in number of coats to achieve specified mil thickness recommended by the manufacturer.
  1. Install integral cove base where indicated on the contract drawings and according to manufacturer's instructions.
  2. Key in all drains, edges, and transition points according to manufacturer's instructions.

- E. Broadcast aggregates in accordance with the specified system and manufacturer's instructions.
- F. Adhere to all limitations, instructions, and cautions for epoxy coating as stated in the manufacturer's published literature.

#### 3.04 FIELD QUALITY CONTROL

- A. Verify coatings and other materials are as specified.
- B. Verify coverages of the system as work progresses. Areas found not to meet the required thickness shall receive additional material until specified thickness is attained.
- C. Manufacturer's representative shall provide technical assistance and guidance for surface preparation and application of coating systems.

#### 3.05 PROTECTION AND CLEAN-UP

- A. Prohibit traffic on floor for 48 hours after installation. Avoid heavy abrasion and chemical exposure for 5 days. Allow 72 hours minimum for vehicular traffic.
- B. Protect finished surfaces of coating system from damage during construction.
- C. Touch-up, repair or replace damaged flooring system after substantial completion.
- D. Clean area and remove all debris upon completion of work. Dispose of empty containers properly according to current Local, State and Federal regulations.

#### 3.06 MAINTENANCE

- A. Contractor shall provide to owner, maintenance and cleaning instructions for the floor system upon completion of work. Owner is required to clean and maintain the surfaces to maintain manufacturer's warranty.

### **END OF SECTION**

*This guide specification has been prepared by Westcoat Specialty Coating Systems to assist design professionals in developing a project specific specification. This guide is a template that must be reviewed and adapted by specifiers to comply with project requirements. This guide specification is not to be copied directly into a project specification manual without review.*





**westcoat**®  
SPECIALTY COATING SYSTEMS

# COLOR CHART



Travatan I 40



Tile Red I 34



Deep Tan I 27

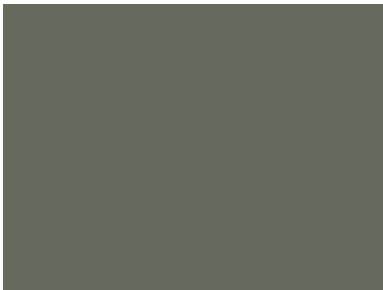

Pewter Gray I 12



Cape Cod Gray I 41



Concrete Gray I 52

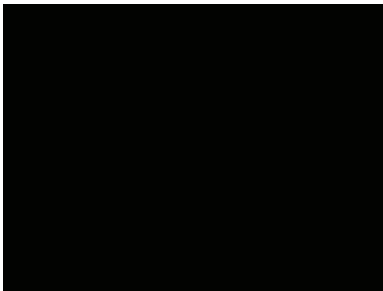

Black I 56



Stone Gray I 42



Safety Red I 90



Safety Yellow I 91



Safety Blue I 92



Safety Green I 93

\* Also available in White | 00

\* Custom color matching also available in EC-11, EC-12, EC-34, EC-95 and EC-102 with a 20 gallon minimum and \$250.00 color matching fee.



**CAUTION :**

Color will vary between products and sheens. This chart is for reference only.  
Please request an actual color sample or apply sample on site before beginning any project.





**westcoat**®  
SPECIALTY COATING SYSTEMS

# **SAMPLE WARRANTY**

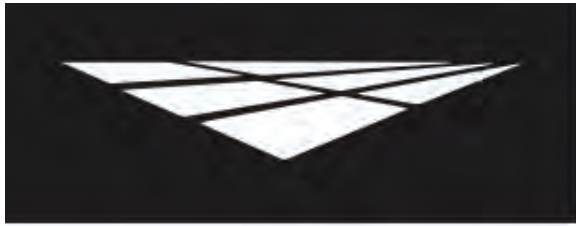

# WARRANTY

---

## WESTCOAT EPOXY SLURRY SYSTEM MATERIAL WARRANTY

Westcoat warrants the Westcoat Epoxy materials to be free of defects in the material for a period of one (1) year from the date of original purchase of the materials provided that the materials are installed by a factory trained state-licensed contractor enrolled in the Westcoat QCA and subject to all terms and conditions set forth below.

If the Westcoat Epoxy materials fail due to defects within the warranty period, Westcoat, at its sole discretion, will either provide replacement materials for the defective Epoxy materials or reimburse the original purchaser in an amount not to exceed the original cost of the materials. Westcoat shall in no way be responsible or liable for any labor costs or any incidental or consequential damages, including without limitation, economic losses, loss profits, business interruption, loss of use, contribution, indemnity or other losses arising from the use of the Epoxy materials.

This warranty does not apply to and Westcoat has no responsibility or liability for: (1) moisture rising from the substrate and/or efflorescence; (2) cracks due to movement of substrate; (3) surfaces other than 2500 psi concrete; (4) waterproofing of any sort (5) maintenance, (6) loss of gloss, fading, and cleaning (7) sloping.

This warranty is void if the Epoxy materials are: not properly maintained; not installed pursuant to the current system information sheet; and/or applied at any area that is not built in accordance with applicable building codes. The warranty is also void if all of the materials are not purchased from an authorized distributor of Westcoat.

THIS MATERIAL WARRANTY AND THE REMEDIES PROVIDED HEREUNDER ARE EXCLUSIVE AND GIVEN IN LIEU OF ALL OTHER WARRANTIES (WHETHER WRITTEN, ORAL, IMPLIED OR STATUTORY). THERE ARE NO OTHER WARRANTIES, EITHER EXPRESSED OR IMPLIED, INCLUDING BUT NOT LIMITED TO, WARRANTIES OF MERCHANTABILITY AND FITNESS FOR A PARTICULAR PURPOSE, THAT EXTEND BEYOND THAT SPECIFICALLY DESCRIBED HEREIN. PURCHASER'S SOLE AND EXCLUSIVE REMEDY AGAINST THE MANUFACTURERS OF WESTCOAT, INCLUDING CLAIMS BASED UPON THE MANUFACTURER'S NEGLIGENCE OR STRICT LIABILITY, SHALL BE LIMITED SOLELY TO THE REPLACEMENT OF ANY DEFECTIVE EPOXY MATERIAL OR A PAYMENT BY THE MANUFACTURER IN AN AMOUNT EQUAL TO THE COST OF THE ORIGINAL EPOXY MATERIAL.

Any and all disputes, claims or damages arising out of the use of Epoxy materials or this Warranty shall be arbitrated in the County of San Diego, State of California, utilizing the services of a neutral dispute resolution service upon which the purchaser and the manufacturer agree, or if they cannot agree, utilizing the services of the American Arbitration Association. The purchaser and the manufacturer hereby waive any right they may have to have a jury decide any dispute.

All claims arising from any defect in the Epoxy materials or under this Warranty shall be presented to the manufacturer within ninety (90) days of the discovery of the alleged defect. Upon notification, Westcoat shall have the right to inspect and determine course of repair. The absence of a written claim within this time period shall constitute a waiver of all claims, rights and damages against the manufacturer. This warranty is non-transferable.



**westcoat**<sup>™</sup>

4007 Lockridge Street San Diego, CA 92102  
800•250•4519 • Fax 619•262•8606 • westcoat.com



**westcoat**®  
SPECIALTY COATING SYSTEMS

# GENERAL MAINTENANCE



## INTERIOR COATINGS

Westcoat interior coating systems (including systems such as Thin Film, Grind and Seal, Dubro Quartz, etc.) offer durable, high-performance, long lasting surfaces that are designed to provide years of service against normal wear and usage. Seamless flooring allows for greater ease of cleaning, compared to traditional resilient flooring, due to the absence of cracks, seams, and crevices that can trap dirt and contaminants. To extend the service life of your Westcoat system, it is recommended to implement a routine cleaning regimen and have periodic inspections. This information is a basic guideline only.

### **Routine Cleaning**

All coating systems require maintenance and upkeep to ensure continued performance and to maximize the life of the system. Maintenance methods may vary depending on the system, texture, topcoat or sealer, environment conditions, slope, drainage, volume and type of traffic, and use of space.

Ensure that the coating surface is free from debris, such as sand, gravel, metals, or other abrasives that can result in premature wear of the topcoat or sealer. Grease, oils, and other contaminants should be removed promptly to maintain the surface. Establish a routine maintenance schedule for all flooring systems. Be sure to test all cleaning agents in an unnoticeable area to ensure compatibility. Refer to the manufacturer's instructions and dilution rates for all cleaning agents. Routine cleaning can be achieved by using a mild cleaning solution, such as "Simple Green", neutral pH detergent, or soap. Be sure to use clean mops and change out cleaning solution regularly. Utilize a brush, broom, or mechanical scrubber to help agitate and loosen up dirt and debris, especially on textured floors. Ensure that the surface is rinsed with clean water thoroughly. Do not allow cleaning agents to dry on the surface. Buildup of residue or other foreign elements can make cleaning more difficult and can also negatively affect the slip-resistance of the surface.

Floor auto-scrubbing machines can be used for larger areas. Avoid using abrasive pads or brushes and use long, soft brushes. Do not allow buildup of residue or other foreign materials, as this can result in a surface that is slippery when wet. Do not use metal-based or coarse brushes, as they may damage the surface.

### **Wax and Floor Finishes**

Westcoat interior coating systems do not typically require a wax or a floor finish material. That said, in some cases where heavy traffic is present or where you may desire to enhance the finish, a standard, commercial floor finish that is intended for use with resinous materials can be applied. Prior to application, ensure that the surface is clean and free from any debris or wax. Apply and





## INTERIOR COATINGS

maintain wax or floor finish per the manufacturer 's guidelines. Wax or floor finishes will need to be completely removed prior to reseal application.

### Maintenance and Inspections

All interior coating systems should be periodically inspected and regularly maintained by a Westcoat Qualified Contractor Applicator (QCA). Inspections are required one year after installation and every two years thereafter by a factory authorized representative. After 3-5 years, a "reseal" (thorough cleaning and reapplication of Westcoat topcoat/sealer) may be required. Existing sealer or coating should be abraded and wiped with solvent before application of topcoat or sealer. Some topcoats and sealers may require additional preparation prior to recoating. Should damage occur, be sure to contact the original Westcoat applicator to inspect and repair the coating system immediately.

### Best Practices

- Do not expose the coating surface to traffic, moisture, or chemical agents until system is fully cured.
- Immediately clean up and rinse off any chemical solutions that may stain or damage the surface.
- Do not subject the floor coating system to chemicals that it is not compatible or resistant to.
- Avoid dragging metal, concrete, pallets, or other types of objects with sharp edges across the floor.
- Rolling loads with steel casters can potentially damage the surface and should be avoided.
- Avoid ponding or standing water by ensuring that positive drainage is present before applying the floor coating system.
- Water should not be allowed to enter the flooring system through penetrations, joints, or edges.
- Furniture should have protective coasters or pads to prevent from indentations or damage.
- Tape and other adhesives should not be applied to finished floors as, this may damage the surface.

Any information provided by Westcoat Specialty Coating Systems is for general purposes only. Nothing presented by Westcoat Specialty Coating Systems constitutes design advice or a recommendation specific to a particular situation. Westcoat Specialty Coating Systems directs you to consult with the appropriate qualified design professional to ensure any product or information meets the requirements for the specific intended use, and complies with all building plans, specifications, codes or regulations. Westcoat Specialty Coating Systems expressly and specifically disclaims responsibility for any damages arising from the use of any information, and each recipient of this information agrees that there is no express or implied warranty, including any implied warranty of merchantability or fitness for a particular purpose, arising from any information provided by Westcoat Specialty Coating Systems.



**westcoat**®  
SPECIALTY COATING SYSTEMS

# ARCHITECTURAL DETAILS



## HIGH BUILD EPOXY FLOORING TRANSITION TO ALTERNATE FLOORING

NOT TO SCALE

### NOTES:

- 2500 PSI MINIMUM CONCRETE SUBSTRATES
- SEE ICRI STANDARDS FOR PROPER CONCRETE PREP
- REFER TO LOCAL BUILDING CODES AND DEPARTMENT OF ENVIRONMENTAL HEALTH STANDARDS

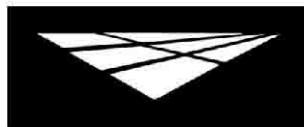
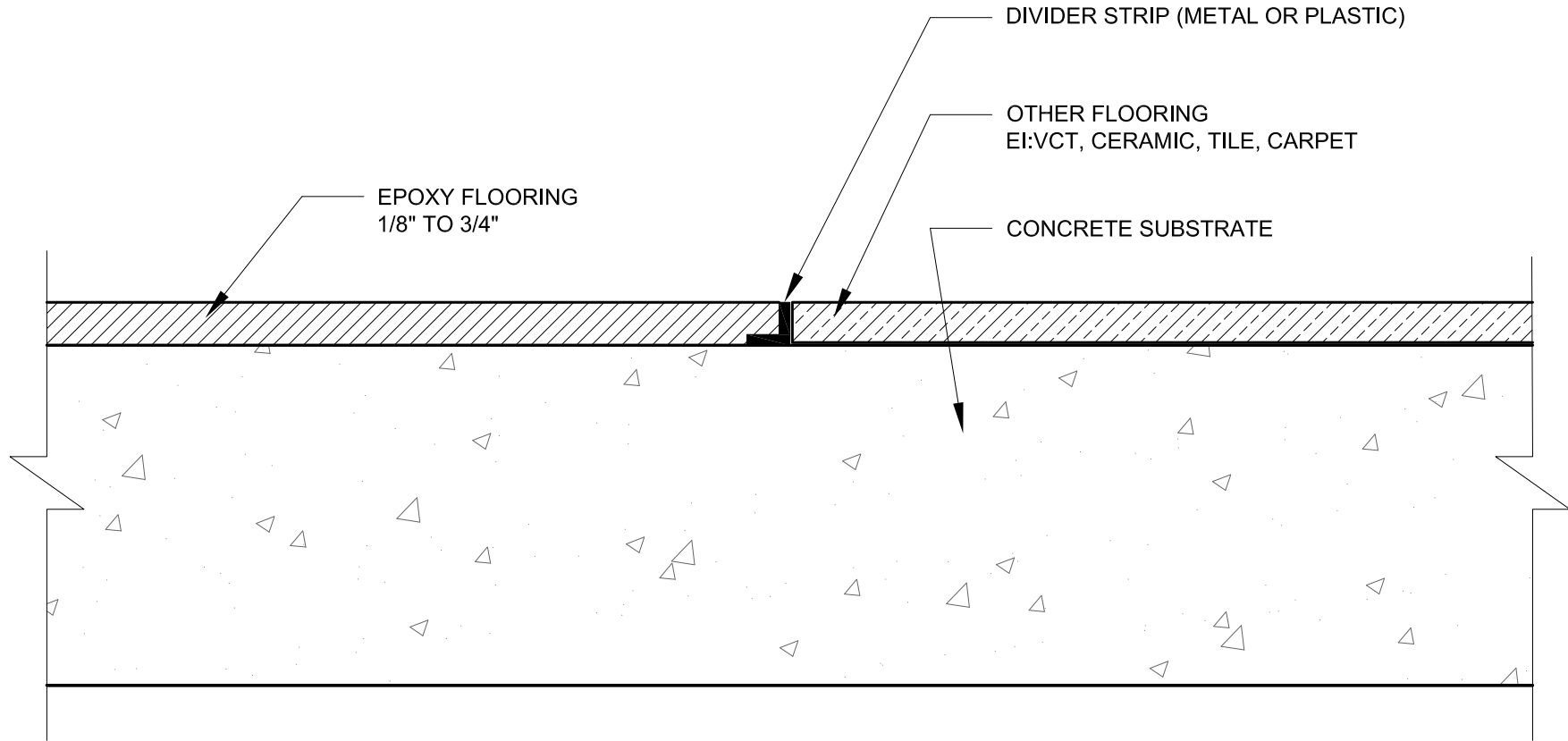

**westcoat**

800-250-4519  
4007 LOCKRIDGE STREET

www.westcoat.com  
SAN DIEGO, CA. 92102

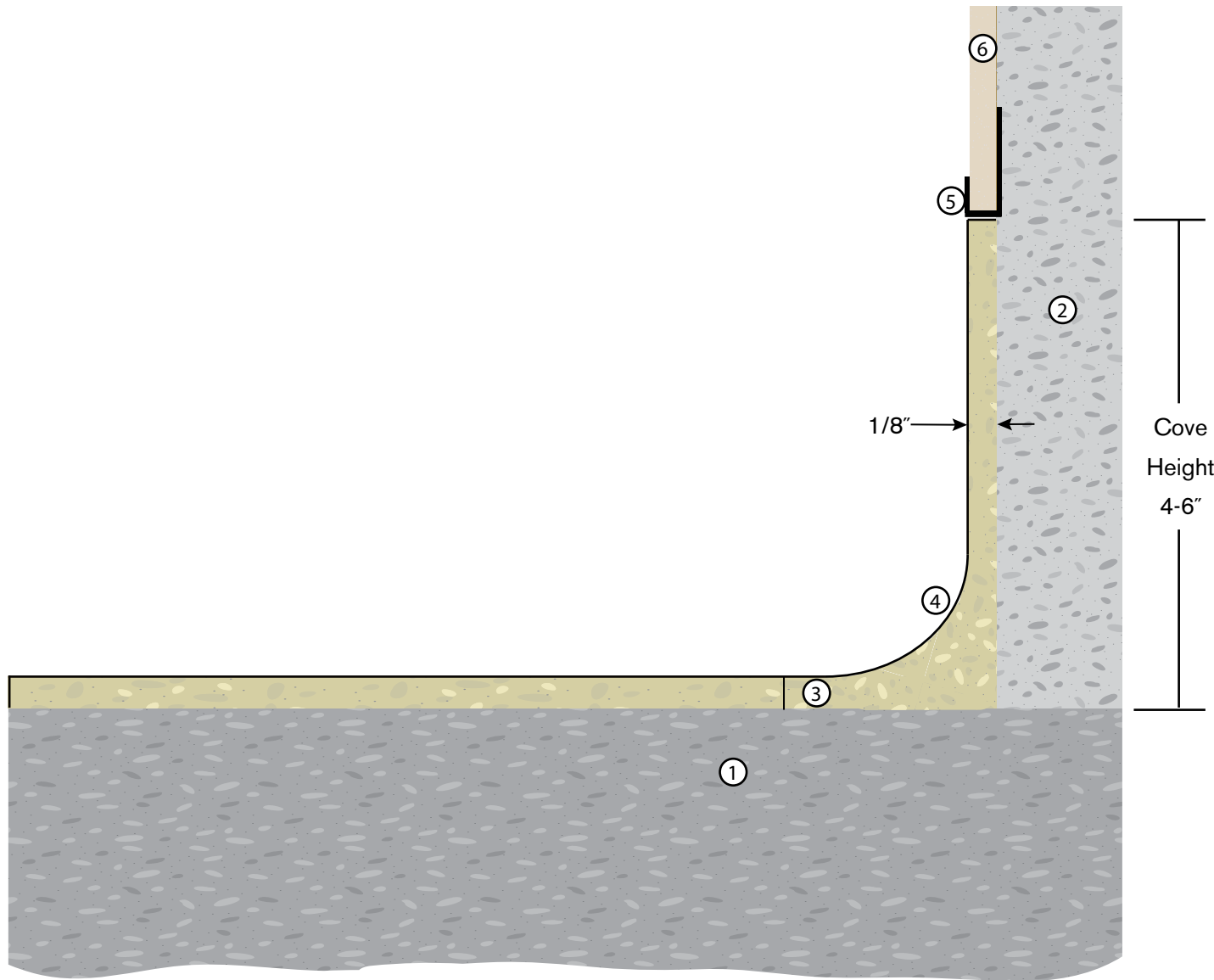

## KEYNOTES

- ① Concrete Substrate
- ② Wall
- ③ Epoxy Flooring System
- ④ 3/4 Radius Cove
- ⑤ FRP Edge Trim Molding
- ⑥ FRP

- Concrete must be a minimum 2,500 PSI.
- Concrete must be cured for a minimum 28 days.
- Concrete should be prepared to a profile equal to ICRI CSP 3-5.
- Refer to local building codes and standards.
- Refer to all Product and System Specifications for additional information.

REV. 12/15/20 - TC

### EPOXY COVE - FRP PANEL TERMINATION

DIVISION 09 67 23  
Resinous Flooring

SCALE : NTS



**westcoat**  
SPECIALTY COATING SYSTEMS

4007 Lockridge Street • San Diego, CA • 92102  
800.250.4519 • westcoat.com

## HIGH BUILD EPOXY TO CONCRETE FLOOR TERMINATION

NOT TO SCALE

### NOTES:

- 2500 PSI MINIMUM CONCRETE SUBSTRATES
- SEE ICRI STANDARDS FOR PROPER CONCRETE PREP
- REFER TO LOCAL BUILDING CODES AND DEPARTMENT OF ENVIRONMENTAL HEALTH STANDARDS

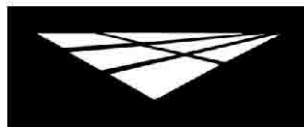
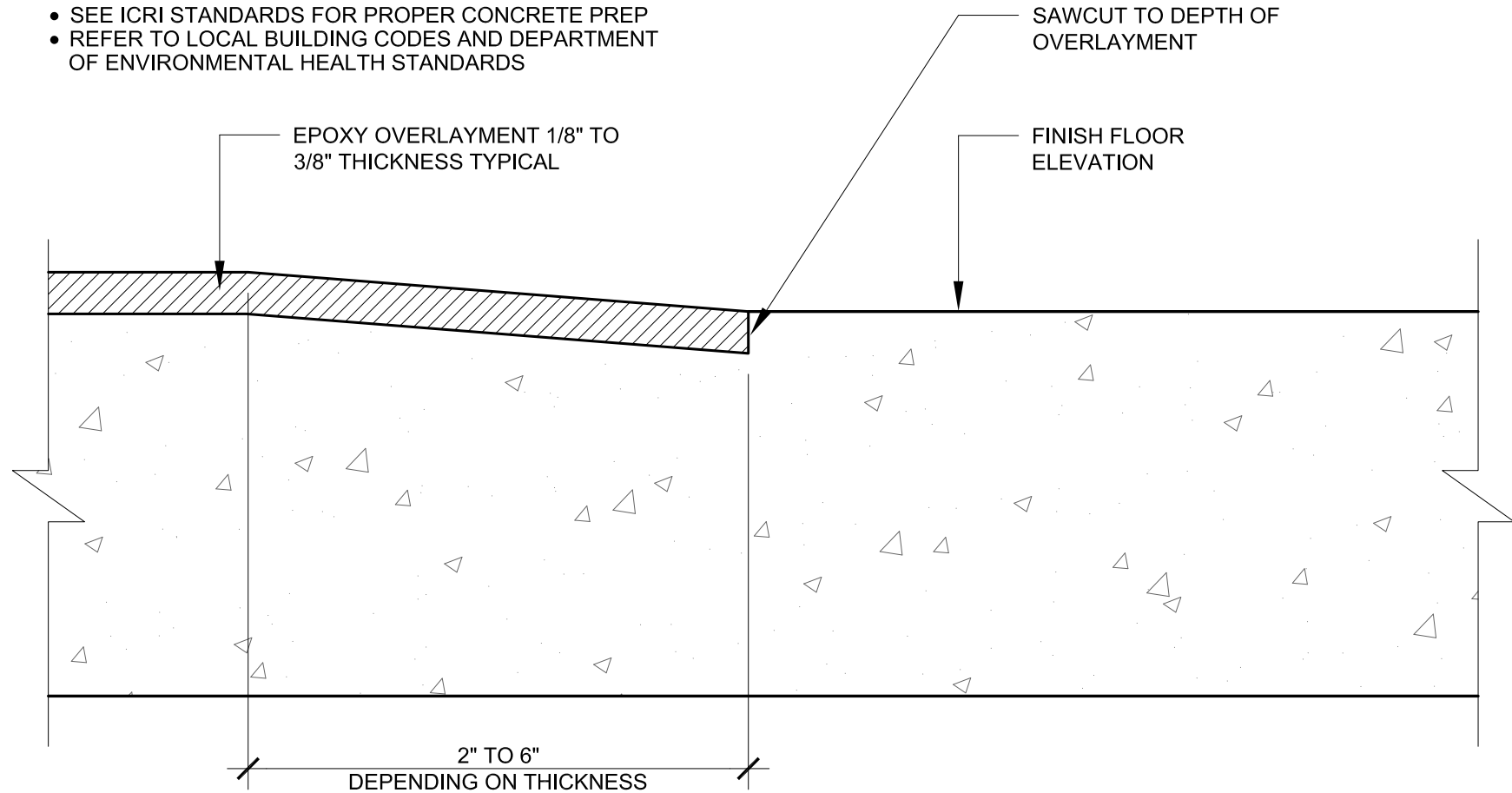

# westcoat

800-250-4519  
4007 LOCKRIDGE STREET

www.westcoat.com  
SAN DIEGO, CA. 92102

EC FLOOR DRAIN  
NOT TO SCALE

NOTES:

- 2500 PSI MINIMUM CONCRETE SUBSTRATES
- SEE ICRI STANDARDS FOR PROPER CONCRETE PREP
- REFER TO LOCAL BUILDING CODES AND DEPARTMENT OF ENVIRONMENTAL HEALTH STANDARDS
- CHIP OUT AROUND DRAINS TO A DEPTH AT LEAST THE DEPTH OF THE FLOOR TOPPING

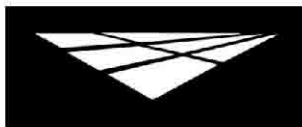
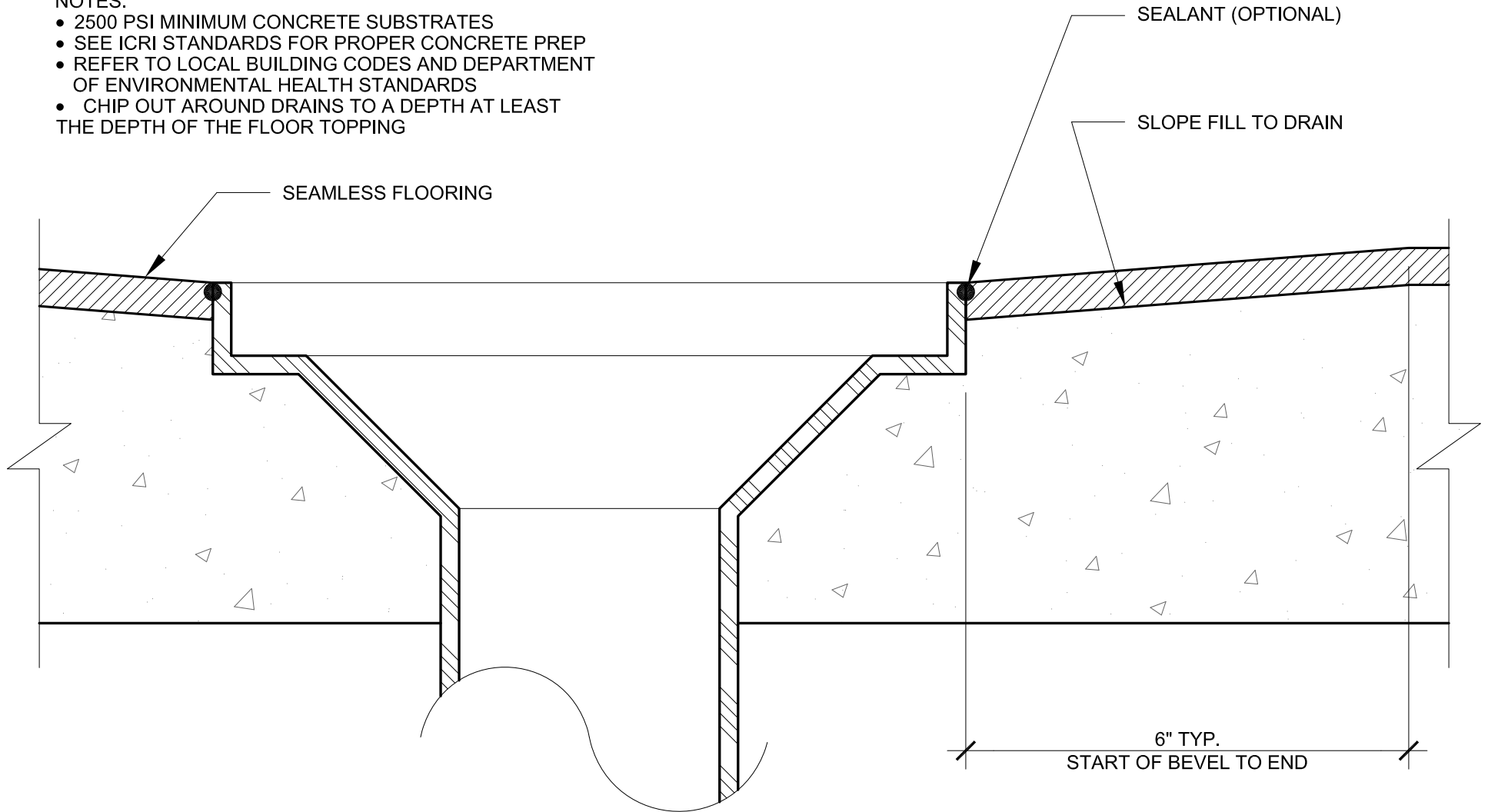

**westcoat**

800-250-4519  
4007 LOCKRIDGE STREET

www.westcoat.com  
SAN DIEGO, CA. 92102

## CRACK REPAIR: HIGH BUILD SYSTEMS

NOT TO SCALE

### NOTES:

- 2500 PSI MINIMUM CONCRETE SUBSTRATES
- SEE ICRI STANDARDS FOR PROPER CONCRETE PREP
- REFER TO LOCAL BUILDING CODES AND DEPARTMENT OF ENVIRONMENTAL HEALTH STANDARDS

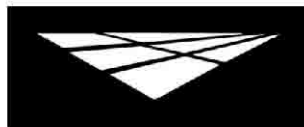
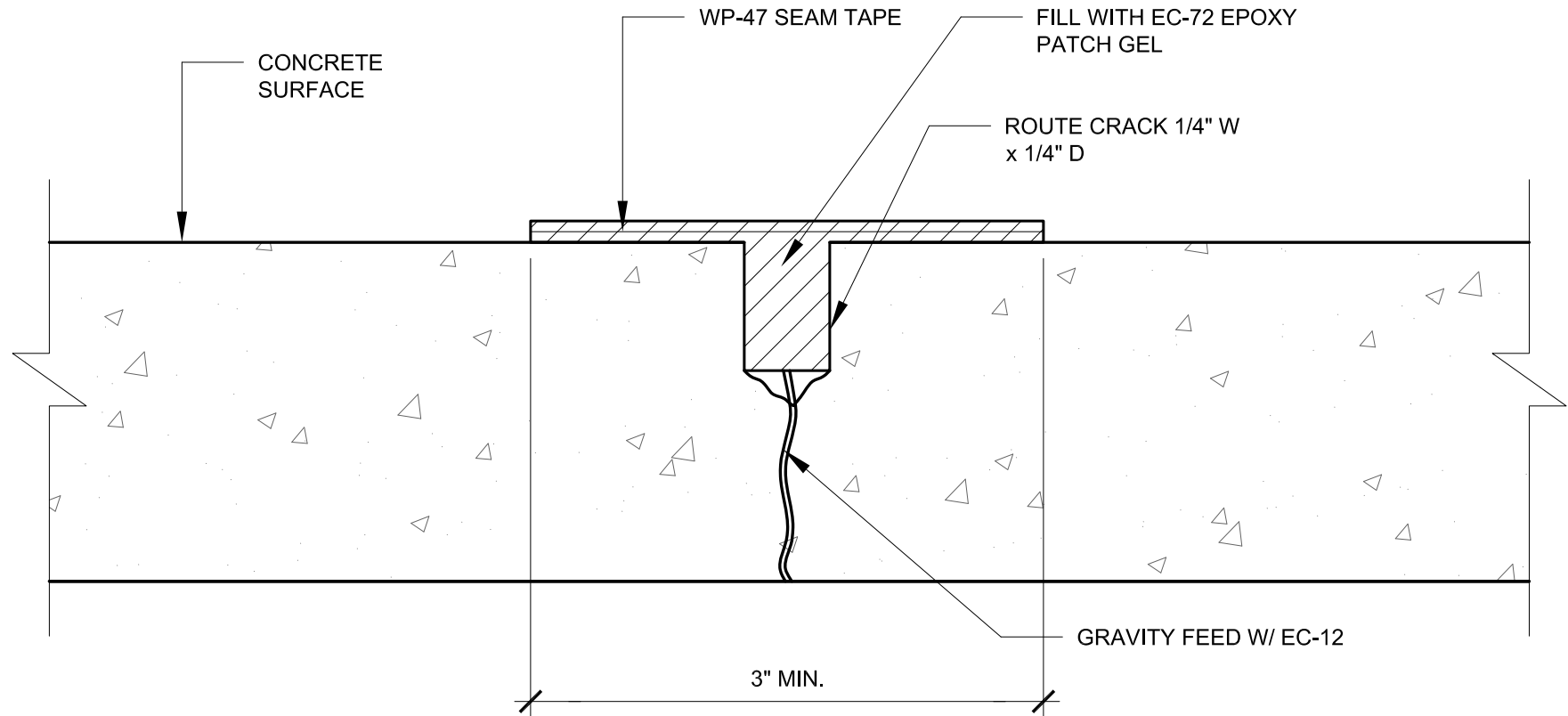

# westcoat

800-250-4519  
4007 LOCKRIDGE STREET

[www.westcoat.com](http://www.westcoat.com)  
SAN DIEGO, CA. 92102

**EC COVE**  
NOT TO SCALE

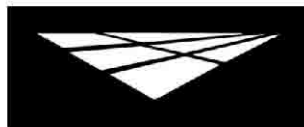
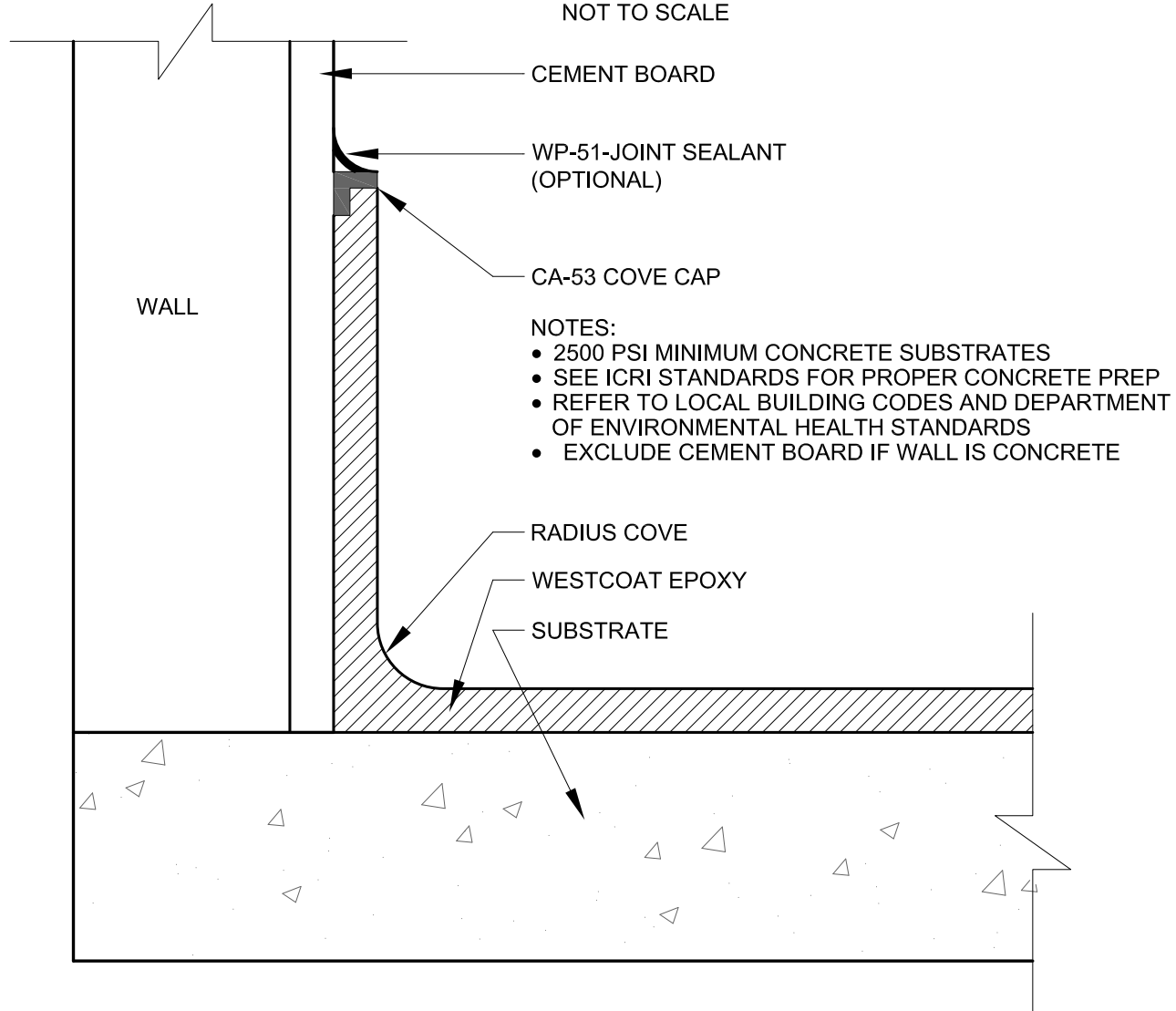

**westcoat**

800-250-4519  
4007 LOCKRIDGE STREET

www.westcoat.com  
SAN DIEGO, CA. 92102