

westcoat®

ALX PRO SOLAR REFLECTIVE FINISH



WATERPROOF

RELIABLE MOISTURE BARRIERS

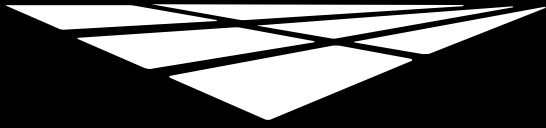

westcoat®

ALX PRO SOLAR REFLECTIVE FINISH SUBMITTAL PACKAGE

**DIVISION 7 – THERMAL AND MOISTURE PROTECTION
SECTION 07 18 13 PEDESTRIAN TRAFFIC COATINGS
PLYWOOD SURFACES**

TABLE OF CONTENTS

System Brochure	3-6
System Specification Sheet	7-13
CSI Specification	14-19
Evaluation Report	20-28
Color Chart	29-31
Sample Warranty	32-33
General Maintenance	34-36
Architectural Details	37-59

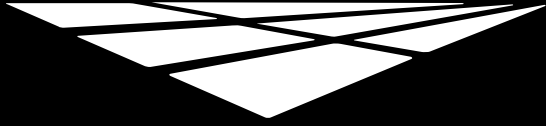

westcoat®

SYSTEM BROCHURE



ER 587



ABOUT ALX

Experience unmatched strength, durability, and design with ALX™, Westcoat’s waterproof deck coating system. Formulated for plywood surfaces, the ALX system integrates acrylic resins and cement blends into a reinforced, galvanized metal lath. Transform an interior wood subfloor to a decorative concrete or epoxy finish with ALX Underlayment system - a blank slate for installing tile, epoxy or other decorative flooring options.



REBUFFS RAIN, SNOW + SPILLS.

- Extensive Testing and Certifications
- Provides Early Protection After Framing
- Low Maintenance
- Unlimited Decorative Options
- Cost Effective
- Exterior or Interior
- Solar Reflective Option is CRRC approved.



FOR PROFESSIONAL USE ONLY.





**IAPMO ER-587 • Class A and One Hour Fire Rated • City of LA Approval
Meets Wildland Urban Interface (W.U.I) Requirements**

THE SYSTEM

Westcoat ALX is a waterproof walking deck system that is reinforced with metal lath and installed with a series of three separate polymer-modified cementitious applications and sealed with Westcoat's SC-10 Acrylic Topcoat or clear sealer. The finished system weighs approximately 2½ lbs per square foot and is less than a 1/4" thick. ALX gives plywood the look and feel of concrete with a decorative appeal. This system can be installed with a custom finish for exterior or interior. Go ALX Pro with an added layer of fiberlath reinforced membrane.

ALX PRO Standard Finish

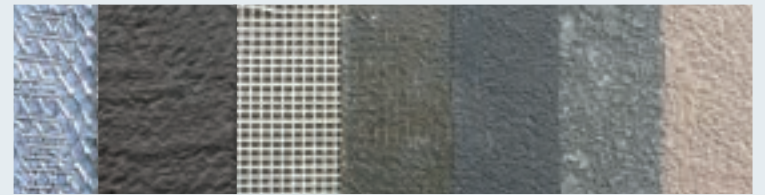

Sheet Membrane w/ Metal Lath Base Coat Fiberlath w/ Resin Membrane Slurry Coat Texture Coat Topcoat

INTERIOR

ALX Interior transforms a plywood subfloor into a concrete-like finish. Finish this system with a smooth decorative coating such as a microtopping or epoxy flooring system.

ALX Interior

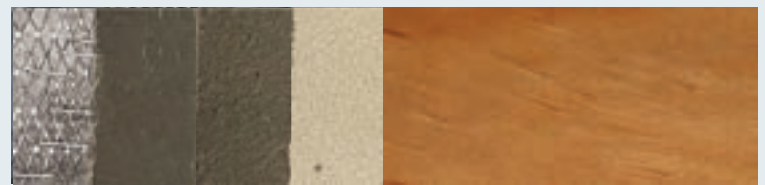

Sheet Membrane w/ Metal Lath Base Coat 2nd Base Coat Slurry Coat Custom Finish (Shown Here with Liquid Dazzle)

WATERPROOFING UNDERLAYMENT

This process is for waterproofing plywood decks to receive tile, stone, or concrete as the finished look. Protect your plywood right after framing and allow for other trades to "traffic" during the construction process.

ALX UNDERLAYMENT

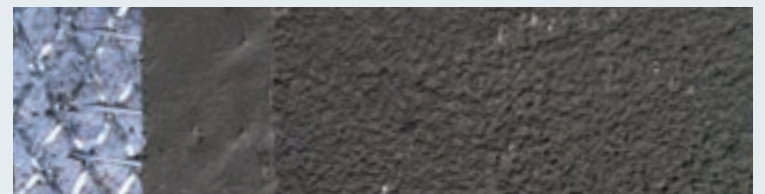

Sheet Membrane w/ Metal Lath Base Coat Slurry Coat





westcoat
SPECIALTY COATING SYSTEMS

SOLAR REFLECTIVE FINISH

Westcoat's Solar Reflective Finish System is a series of polymer-modified, white cementitious coatings that are bonded to the concrete or applied over specific Westcoat Systems, then sealed with Westcoat's Solar Reflective SC-10 Acrylic Topcoat.

APPLICABLE SYSTEMS

ALX Standard | ALX Pro Standard

MACoat Standard | Texture-Crete Standard

ADVANTAGES

- Meets California Title 24 Cool Roof Requirements
- Solar Reflective Topcoat
- Cost Effective
- Fast Drying
- Low Maintenance
- Long Lasting

SC-10-SR Gray

SRI
84



SC-10-SR Tan

SRI
91

SC **SURFACE COAT**
PROTECTIVE SEALERS & STAINS

westcoat
SPECIALTY COATING SYSTEMS

westcoat.com | 800.250.4519



westcoat®

SYSTEM SPECIFICATION SHEET

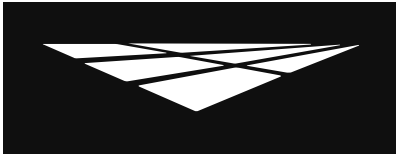

westcoat®

SYSTEM SPECIFICATION

WP

WATERPROOF

RELIABLE MOISTURE BARRIERS

ALX™ Pro Solar Reflective Finish

Description

Westcoat ALX™ Pro Solar Reflective Finish system is a waterproof walking deck system that also meets the Cool Roof requirements of California Title 24*. This bonded system is reinforced with metal lath, a fiberlath reinforced membrane, a series of white polymer-modified cementitious applications and is sealed with Westcoat's Solar Reflective series of SC-10 Acrylic Topcoats, that utilize infrared (IR) pigments. The finished product weighs approximately 2½ lbs per square foot. This system gives plywood the look and feel of concrete with a decorative appeal and also reduces the Urban Heat Island Effect and can lower the surface temperature.

Uses

The ALX™ Pro Solar Reflective Finish system is suitable for commercial and residential environments. Some uses include balconies, corridors and landings. It is regularly specified for hotels, condominiums, apartments and office buildings.

System Overview

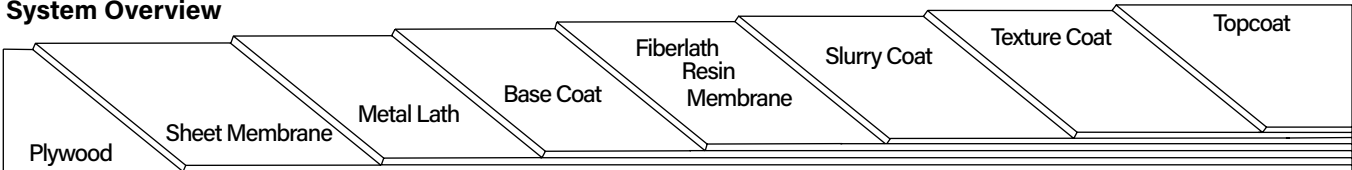

System Data

Coverages	Base Coat	Fiberlath Resin Membrane	Slurry Coat	Texture Coat	Top Coat
	40 ft ² per batch	250 ft ² per batch	100-150 ft ² per batch	150-300 ft ² per batch	200-400 ft ² per gallon
Components	WP-10 Staples			Shelf Life	ER-587
	WP-25 Metal Lath			N/A	
	WP-40 Sheet Membrane			N/A	
	WP-47H Fiberlath Heavy Duty			1 year	
	WP-51 Polyurethane Sealant			5 years	
	WP-81 Cement Modifier			1-2 years	
	WP-90 Waterproofing Resin			2 years	
	SC-10 Solar Reflective Acrylic Topcoat			2 years	
	TC-1W White Basecoat Cement			1 year	
TC-2 Smooth Texture Cement			1 year		
Certifications	IAPMO ER-587 Meets Class A Fire Test ASTM E-108 Meets One-Hour Fire Rating ASTM E-119 Meets Class I Vapor Retarder ASTM E96 (when WP-40 is installed over entire deck) Meets Wildland Urban Interface (W.U.I) Requirements Meets the Requirements of Decking SFM 12-7A-4 Parts A & B Meets 2020 City of Los Angeles Building and Residential Code (LABC & LARC) CRRC Product ID# 1316-0001: Solar Reflective Finish SC-10-SR Gray CRRC Product ID# 1316-0002: Solar Reflective Finish SC-10-SR Tan				

DISCLAIMER: PURCHASER'S SOLE AND EXCLUSIVE REMEDY AGAINST THE MANUFACTURER OF WESTCOAT, SHALL BE LIMITED SOLELY TO THE REPLACEMENT OF ANY DEFECTIVE MATERIAL OR A PAYMENT BY THE MANUFACTURER IN AN AMOUNT EQUAL TO THE COST OF THE ORIGINAL MATERIAL.



4007 Lockridge St • San Diego, CA 92102
800-250-4519 • Fax 619-255-7187 • westcoat.com

1 of 6
ALX™ Pro - SRF 10/24

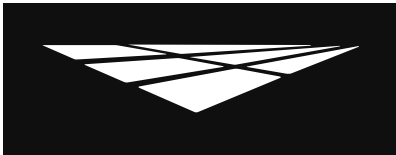

westcoat®

SYSTEM
SPECIFICATION

WP

WATERPROOF
RELIABLE MOISTURE BARRIERS

ALX™ Pro Solar Reflective Finish

Advantages

Meets California Title 24 Requirements* • Helps Reduce the Urban Heat Island Effect • Lowers the Surface Temperature • Quick Access After Installation • Waterproof • Excellent Sound Reduction Qualities • Tough Final Coat is UV Resistant • Covers Rough Plywood and Seams • Skid Resistant Finish • Decorative Finishes Available • Unmatched Strength and Durability • Fiberlath Reinforced Membrane • Cost Effective • Available Manufacturer's Warranty

Inspection

For installation of the ALX™ Pro system, plywood must be a minimum of 5/8 inch (3/4 inch preferred) CDX or exterior grade. For applications over pressure-treated lumber, please contact your Westcoat Representative prior to application. Slope must be a minimum of 1/4 inch per linear foot to allow for proper drainage. Decks should meet local building codes. The deck shall be tongue and groove, completely blocked and nailed (glued and screwed is best). Plywood shall have a maximum joist span of 16 inches. Deflection should be less than L/360. OSB is not a suitable substrate for this material. Moisture vapor commonly collects in areas below a vapor barrier, such as the waterproofing membrane of the deck covering system. Venting must be added to help relieve moisture vapor transmission. Please refer to all local building codes regarding venting requirements.

Preparation

Be sure the surface is clean, dry and free of grease, paint, oil, dust or any foreign material that may prevent proper adhesion. "Dry" plywood is typically defined as having less than a 10% moisture reading or by showing no moisture with a plastic sheeting test. Applicator is responsible for ensuring that the substrate is acceptable for application. Do not apply to wet plywood.

Sheet Membrane

Westcoat requires the installation of 6 inch WP-40 Sheet Membrane to all plywood seams for reinforcement. For maximum protection, WP-40 36 inch, can be applied to the entire deck. WP-40 may also be installed behind or on top of the flashing as a backup waterproofing measure. For increased adhesion, WP-43 Sheet Membrane Primer may be used prior to applying the Sheet Membrane. WP-40 may not be left exposed to the sun for more than 7 days. See WP-40 Sheet Membrane and WP-43 Sheet Membrane Primer Product Specification Sheets for additional information.

Flashing

Westcoat requires a minimum of 26-gauge bonderized sheet metal. Use 4 x 4 inch 'L' flashing at the junction of the wall and deck. Use 2 x 4 inch drip edge flashing for fascia edge. Overlap all ends at least four inches. Apply two beads of WP-51 Polyurethane Sealant or WP-53 Hybrid Sealant to all seams. Nail flashing every 4-6 inches. (Note: If the flashing is not bonderized, it must be prepared in accordance with SSPC-SP11 surface preparation standards, in order for the coating to adhere properly).

DISCLAIMER: PURCHASER'S SOLE AND EXCLUSIVE REMEDY AGAINST THE MANUFACTURER OF WESTCOAT, SHALL BE LIMITED SOLELY TO THE REPLACEMENT OF ANY DEFECTIVE MATERIAL OR A PAYMENT BY THE MANUFACTURER IN AN AMOUNT EQUAL TO THE COST OF THE ORIGINAL MATERIAL.



westcoat®

4007 Lockridge St • San Diego, CA 92102
800-250-4519 • Fax 619-255-7187 • westcoat.com

2 of 6
ALX™ Pro - SRF 10/24

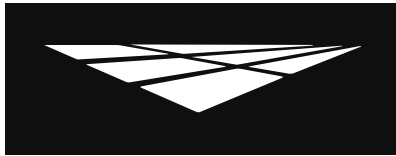

westcoat®

SYSTEM
SPECIFICATION

WP

WATERPROOF
RELIABLE MOISTURE BARRIERS

ALX™ Pro Solar Reflective Finish

Metal Lath

Place the WP-25 Metal Lath on the plywood and cut it to fit the area ensuring the edge of the lath is offset two inches from any parallel plywood seams. The lath should run across the grain of the plywood (across the long seams) when possible. The grain of the lath should be placed so that it curves down at the edge of the deck. The metal lath should be held back 2 inches from all deck edges, leaving 2 inches of flashing exposed. With the lath in place, start in the center working your way out. Staple the lath using 16-20 staples per square foot (minimum 1 inch crown x $\frac{5}{8}$ inch long, 16-gauge non-corrosive Senco P10). Overlap the lath 1-2 inches and staple every 1-2 inches along the seam. With a hammer, lightly pound down any seams or staples that are higher than the lath.

Base Coat

Pour $1\frac{1}{4}$ gallons of WP-81 Cement Modifier and desired water (up to one quart) into a clean mixing bucket and then add one bag of TC-1W White Basecoat Cement. Mix until uniform with a mechanical mixer at a low rpm. Pour the mixture ($4\frac{1}{2}$ gallons total) onto the lath and with trowel on edge, smooth the mixture to the top of the lath at the rate of 40 square feet per batch. Trowel and brush the base coat up to the metal lath edge, leaving 2 inches of flashing exposed. For best results, tape off the flashing. Use a paintbrush to spread the base coat into all corners. Tap the deck lightly with a hammer to help in smoothing out trowel ridges. As soon as it is dry, usually 1 to 2 hours at 70 degrees, scrape off any high spots or ridges, before applying the Fiberlath Resin Membrane.

Fiberlath Resin Membrane

Lay out WP-47 Fiberlath reinforcing mesh on the deck, overlapping the seams approximately 2 inches. The Fiberlath should be held back $\frac{1}{2}$ inch from all deck edges, leaving $\frac{1}{2}$ inch of flashing exposed. Combine one bag of TC-1W White Basecoat Coat Cement with five gallons of WP-90 Waterproofing Resin. Mix with a mechanical mixer until uniform. Pour the mixture into the WP-47, trowel thin and smooth at the coverage rate of approximately 250 square feet per batch, stopping at the Fiberlath edge, leaving $\frac{1}{2}$ inch of flashing exposed. For best results, tape off flashing. Use a paintbrush to spread the base coat ensuring the mixture covers all seams and corners. Allow surface to dry for 1-4 hours at 70 degrees. Scrape off any high spots or ridges prior to application of the Slurry Coat. Trim any mesh that is showing on perimeters after the material has hardened.

Slurry Coat

Create the slurry coat by adding one gallon of WP-81 Cement Modifier and up to $\frac{1}{2}$ gallon of water into a clean mixing bucket and add one bag of TC-1W White Basecoat Cement. Mix until uniform with a mechanical mixer at a low rpm. Trowel the slurry mix over the surface to achieve a smooth finish. Coverage of the slurry coat is between 100-150 square feet per batch. The Slurry Coat will be applied right up to all of the deck's edges. Use a paintbrush to spread the slurry coat onto the flashing, ensuring the mixture coats all corners. Using a brush wet with water, feather all outside edges. After surface is dry (usually 30 minutes to 2 hours at 70 degrees), scrape or grind off any ridges or trowel marks.

DISCLAIMER: PURCHASER'S SOLE AND EXCLUSIVE REMEDY AGAINST THE MANUFACTURER OF WESTCOAT, SHALL BE LIMITED SOLELY TO THE REPLACEMENT OF ANY DEFECTIVE MATERIAL OR A PAYMENT BY THE MANUFACTURER IN AN AMOUNT EQUAL TO THE COST OF THE ORIGINAL MATERIAL.



4007 Lockridge St • San Diego, CA 92102
800-250-4519 • Fax 619-255-7187 • westcoat.com

3 of 6

ALX™ Pro - SRF 10/24

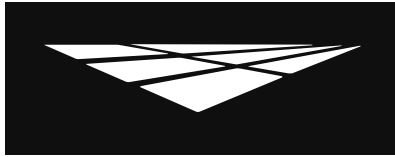

westcoat

**SYSTEM
SPECIFICATION**

WP

WATERPROOF
RELIABLE MOISTURE BARRIERS

ALX™ Pro Solar Reflective Finish

Texture Coat

Pour one gallon of WP-81 Cement Modifier in a clean mixing bucket and add one bag of TC-2 Smooth Texture Cement. Mix thoroughly with a mechanical mixer at a low rpm. Add up to ½ gallon of water to achieve the desired consistency. Texture can be sprayed, troweled or broomed at a rate of about 150 to 300 square feet per batch. After the texture has dried (30 minutes to 1 hour at 70 degrees), lightly scrape any trowel marks and vacuum the surface prior to sealing.

Topcoat

Do not apply if rain is forecast within 48 hours or heavy dew within 24 hours. If multiple batches of SC-10 SR are present, box all materials prior to use, to ensure color consistency. Use a mechanical mixer at a slow speed and mix material until a homogenous mixture and color is obtained. Roll two thin applications of SC-10 SR using a ⅜ inch to ¾ inch roller at a rate of 200-400 square feet per gallon. Roll the material in two directions to achieve a uniform finish. Coverage will vary according to texture. For best results, allow the SC-10 SR 4-6 hours drying time at 70 degrees before permitting light pedestrian traffic or additional coats are applied. Allow 24 hours to cure before heavy traffic is permitted. Allow 48 hours before heavy objects are placed on the surface and allow 72 hours for vehicular traffic. Allow 5 days prior to any abrasion or chemical exposure.

Optional Materials

Sheet Membrane

- WP-40 36 inch can be installed to the entire deck when maximum protection is required.
- WP-43 Sheet Membrane Primer may be used when increased adhesion is desired.

Cement Additives

- CA-15 Cement Accelerator can be added to Westcoat cements to help reduce dry times.
- CA-16 Cement Decelerator can be added to Westcoat cements to increase working time during periods of hot weather.

Skid Resistance

- CA-29 Mini Safe Grip, CA-30 Small Safe Grip or CA-31 Large Safe Grip can be added to the SC-10 Solar Reflective Acrylic Topcoat for added skid resistance.

WP Wrap

- Westcoat's WP Wrap can be used with the ALX System to provide additional waterproofing with reinforcement, along the perimeter of the deck.

Deck Drain

- If a drain is required, Westcoat's WP-35 ALX™ Deck Drain may be installed between the Sheet Membrane and Metal Lath steps in the application instructions. Please read the WP-35 ALX™ Deck Drain Product Specification Sheet for detailed instructions.

Sloping

- Westcoat Slope Technique may be used if additional sloping is required. Slope Technique should be applied after the Base Coat and prior to the Slurry Coat.

* Please refer to Product and System Specification Sheets for additional information.

DISCLAIMER: PURCHASER'S SOLE AND EXCLUSIVE REMEDY AGAINST THE MANUFACTURER OF WESTCOAT, SHALL BE LIMITED SOLELY TO THE REPLACEMENT OF ANY DEFECTIVE MATERIAL OR A PAYMENT BY THE MANUFACTURER IN AN AMOUNT EQUAL TO THE COST OF THE ORIGINAL MATERIAL.



4007 Lockridge St • San Diego, CA 92102
800-250-4519 • Fax 619-255-7187 • westcoat.com

4 of 6
ALX™ Pro - SRF 10/24

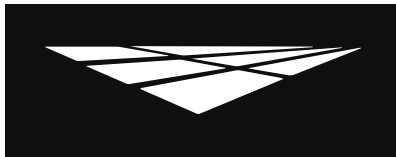

westcoat[®]

**SYSTEM
SPECIFICATION**

WP

WATERPROOF
RELIABLE MOISTURE BARRIERS

ALX™ Pro Solar Reflective Finish

Clean Up

Uncured material can be removed with soap and warm water. If cured, material can be removed mechanically or with an environmentally-safe solvent.

Maintenance

Exterior surfaces can be swept daily with water and a broom. For tougher dirt or grease, use degreaser diluted with water 20:1 and a soft bristle brush or broom. Be sure to rinse well. To remove calcium or lime build up, brush diluted 100 grain vinegar onto the surface; be sure to rinse any residue.

The ALX™ Pro Solar Reflective Finish System should be inspected for wear every 2 to 4 years. The system should be resealed with the appropriate Westcoat SC-10 SR Series Topcoat every 3 to 5 years depending upon traffic and UV exposure. Contact the original installer of Westcoat for complete re-coating instructions.

Health Precautions

Inhalation of vapor or mist can cause headache, nausea, irritation of nose, throat and lungs. Prolonged or repeated skin contact can cause slight skin irritation. Cements contain silicas; dust mask or respirator should be used when mixing, sanding or grinding.

Solvent based products are extremely flammable, extinguish all pilot lights and sources of ignition such as electrical motors. Be sure to have adequate cross ventilation prior to installing.

Limitations

- This system is designed for professional use only.
- Read Product Specification Sheets for every product you will be using before beginning the project.
- Do not apply at temperatures below 50°F or above 90°F.
- Rain will wash away uncured Westcoat acrylic products.
- If inclement weather threatens, cover deck to protect new application.
- Sealers will make the surface slippery, please be aware the texture of the surface and how the sealer will affect the look, feel and skid resistance.
- Approval and verification of proposed colors, textures and slip resistance is recommended.
- Do not allow Westcoat products to freeze.
- Moisture vapor commonly collects in areas below a vapor barrier, such as the waterproofing membrane of the deck covering system. Venting must be added to help relieve moisture vapor transmission. Please refer to all local building codes regarding venting requirements.

Slip Precaution

Westcoat Specialty Coatings Systems highly recommends the use of a slip-resistant additive to all coatings/systems that may be exposed to wet, oily, greasy or slippery conditions. It is the end user's responsibility to provide a flooring system that meets current safety standards. Westcoat and its distributors will not be responsible for injury incurred during a slip and fall incident. For the current coefficient of friction requirements, please consult your local building codes.

DISCLAIMER: PURCHASER'S SOLE AND EXCLUSIVE REMEDY AGAINST THE MANUFACTURER OF WESTCOAT, SHALL BE LIMITED SOLELY TO THE REPLACEMENT OF ANY DEFECTIVE MATERIAL OR A PAYMENT BY THE MANUFACTURER IN AN AMOUNT EQUAL TO THE COST OF THE ORIGINAL MATERIAL.



westcoat[®]

4007 Lockridge St • San Diego, CA 92102
800-250-4519 • Fax 619-255-7187 • westcoat.com

5 of 6
ALX™ Pro - SRF 10/24

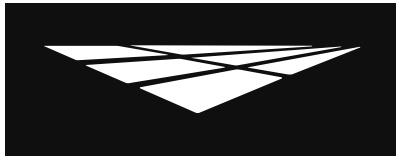

westcoat®

SYSTEM SPECIFICATION

WP

WATERPROOF

RELIABLE MOISTURE BARRIERS

ALX™ Pro Solar Reflective Finish

Test Data

Test	ALX™ Pro Standard WP-40 On Seams	ALX™ Pro Standard WP-40 Full Coverage
Accelerated Aging ASTM D-756	Pass	Pass
Fire-Retardant Roof Covering ASTM E-108	Class A	Class A
One-Hour Fire Test ASTM E-119	Pass	Pass
Fire-Test-Response of Deck Structures to Burning Brands ASTM 2726-12a	Pass	Pass
Under-Deck Fire Test Response of Deck Materials ASTM E2632	Pass	Pass
Water Vapor Transmission of Materials ASTM E96	--	Class I Vapor Retarder (0.1 perm or less)
Bond Strength (Control) ASTM C-297	143 psi	Pass
Bond Strength (Accel. Aging) ASTM-C297	Pass	Pass
Bond Strength (Freeze-Thaw) ASTM C-297	Pass	Pass
Abrasion ASTM D-1242	.023 inches	.023 inches
Water Absorption ASTM D-570	7.5%	7.5%
Chemical Resistance ASTM D-2299	Pass	Pass
Freeze-Thaw ASTM C-67	.5%	.5%
Concentrated Load AC-39 Section 4.12	Pass	Pass
Wind Uplift FM 1-52	Pass	Pass
Impact Resistance ASTM D-3746	Pass	Pass
Solar Reflectance - Initial	Gray: 0.69 Tan: 0.74	Gray: 0.69 Tan: 0.74
Thermal Emittance - Initial	Gray: 0.86 Tan: 0.89	Gray: 0.86 Tan: 0.89
SRI (Solar Reflectance Index) - Initial	Gray: 84 Tan: 91	Gray: 84 Tan: 91

* SC-10 Solar Reflective Acrylic Topcoat is rated to meet the Cool Requirements of California Title 24 when the colors SR Tan or SR Gray are used. Other colors are not rated at this time.

SR Series Color	SRI Value
Butterscotch	84 **
Canvas	84 **
Coconut	71 **
Coral	66 **
Heather Gray	63 **
Lime	78 **
Powder Blue	77 **
Salmon	72 **
Seaside	73 **
SR Gray	84 *
SR Tan	91 *
Wintermint	79 **

* Third-party test data. CRRP Prod. ID# 1316-0001 (SR Gray) & 1316-0002 (SR Tan)

** In-House test data

DISCLAIMER: PURCHASER'S SOLE AND EXCLUSIVE REMEDY AGAINST THE MANUFACTURER OF WESTCOAT, SHALL BE LIMITED SOLELY TO THE REPLACEMENT OF ANY DEFECTIVE MATERIAL OR A PAYMENT BY THE MANUFACTURER IN AN AMOUNT EQUAL TO THE COST OF THE ORIGINAL MATERIAL.



4007 Lockridge St • San Diego, CA 92102
800-250-4519 • Fax 619-255-7187 • westcoat.com

6 of 6
ALX™ Pro - SRF 10/24

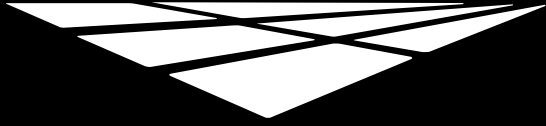

westcoat®

CSI SPECIFICATION



**DIVISION 7 – THERMAL AND MOISTURE PROTECTION
SECTION 07 18 13 PEDESTRIAN TRAFFIC COATINGS
PLYWOOD SURFACE(S)**

PART 1 GENERAL

1.01 SUMMARY

- A. Section includes: Provide a complete acrylic modified cementitious waterproof system for plywood surfaces that meet the requirements for specific use indicated in the contract documents. Include all applicable substrate testing, surface preparation, and detail work.

1.02 RELATED SECTIONS

- A. Specified elsewhere:
1. Section 07 24 00 Exterior Insulation and Finish Systems
 2. Section 09 97 26 Cementitious Coatings
 3. Section 07 01 10.81 Waterproofing Replacement
 4. Section 07 10 00 Damproofing and Waterproofing
 5. Section 07 14 00 Fluid Applied Waterproofing
 6. Section 07 14 16 Cold Fluid Applied Waterproofing
 7. Section 07 16 13 Polymer Modified Cement Waterproofing
 8. Section 09 09 00 Finishes
 9. Section 09 94 00 Decorative Finishing

1.03 REFERENCES

- A. IAPMO – ER-587
B. California Building Code (2019 CBC) & Residential Code (2019 CRC)
C. City of Los Angeles Building Code (2020 LABC) & Residential Code (2020 LARC)
D. Fire Hazard Severity Zone & Wildland Urban Interface (W.U.I.)
E. Class I Vapor Retarder (ASTM E96)
F. ALX Pro meets the Cool Roof Ratings Council (CRRC) Solar Reflective Standards when the colors of SR Gray (product number 1316-0001) and SR Tan (product number 1316-0002) are used.

1.04 SUBMITTALS

- A. Submit under provisions of Section 013300.
B. Product Data: Submit manufacturer's product data sheets on each product and system to be used including:
 1. Preparation instructions and recommendations.
 2. Storage and handling requirements.
 3. Installation methods.
 4. Maintenance requirements.
C. Selection Samples: For each system specified, provide two sets of samples and color charts representing manufacturer's full range of colors and patterns.

1.05 QUALITY ASSURANCE

- A. Cited Standards for reference:
1. Water Vapor Transmission (ASTM E 96)
 2. Bond Strength (ASTM C297)
 3. Accelerated Aging (ASTM D756)

4. Abrasion Resistance (ASTM D1242)
 5. Water Absorption (ASTM D570)
 6. Impact Resistance (ASTM D3746)
 7. Freeze-Thaw (ASTM C67)
 8. Surface Burning (ASTM E84)
 9. Chemical Resistance (ASTM D2299)
 10. Fire Tests of Roof Coverings (ASTM E108)
 11. One-Hour Fire Test (ASTM E119)
 12. Static Coefficient of Friction (ASTM C1028-96)
 13. Compressive Strength (ASTM C109)
 14. Tensile Strength (ASTM C190)
 15. Chemical Resistance (ASTM D2299)
 16. Fire-Test-Response of Deck Structures to Burning Brand (ASTM 2726-12a)
 17. Under-Deck Fire Test Response of Deck Materials (ASTM E2632)
- B. All materials used in the pedestrian traffic system shall be manufactured and provided by a single manufacturer to ensure compatibility and proper bonding.
 - C. Use adequate numbers of skilled workmen thoroughly trained and experienced in the necessary crafts and completely familiar with the specified requirements and methods needed for proper performance of the work of this section.
 - D. Contractor shall have a minimum of 3 years experience installing pedestrian traffic coatings of this type which is required for this project and who is acceptable to the manufacturer.
 1. Applicator shall designate a single individual as project foreman who shall be on site at all times during installation.
 2. Contractor must show and have QCA Qualified Contractor/Applicator paperwork from the manufacturer of the coating system, as required to obtain a long-term jobsite specific warranty.
 - E. Convene a pre-application meeting before the start of application of coating system. Require attendance of parties directly affecting work of this section, including: Architect, contractor, applicator, and authorized representative of the coating system manufacturer and interfacing trades. Review the following:
 1. Drawings and specifications affecting work of this section.
 2. Protection of adjacent surfaces.
 3. Surface preparation and substrate conditions.
 4. Application.
 5. Field quality control.
 6. Protection of coating system.
 7. Repair of coating system.
 8. Coordination with other work.

1.06 DELIVERY, STORAGE & HANDLING

- A. Delivery: Materials shall be delivered to the job site in sealed, undamaged containers. Each container shall be clearly marked with manufacturer's label showing type of material, color, and lot number.
- B. Storage: Store all materials in a clean, dry place with a temperature range in accordance with manufacturer's instructions.
- C. Handling: Handle products carefully to avoid damage to the containers. Read all labels and Material Safety Data Sheets prior to use.

1.07 PROJECT SITE CONDITIONS

- A. Maintain environmental conditions (temperature and weather) within the limits recommended by the manufacturer.
- B. Schedule coating work to avoid rain and excessive dust and airborne contaminants. Protect work areas from moisture and excessive airborne contaminants during coating application.
- C. Before any work is started, the applicator shall examine all surfaces for any deficiencies. Should any deficiencies exist, the architect, owner or general contractor shall be notified in writing and any corrections necessary shall be made.

1.08 WARRANTY

- A. Upon completion of the work in this section provide a written warranty from the manufacturer against defect of materials for a period of 5 (five) years. To obtain project specific warranty the coating system applicator must be a Westcoat Qualified Contractor/ Applicator and apply for warranty.

PART 2 PRODUCTS

2.01 MANUFACTURERS

- A. Acceptable manufacturer: Westcoat Specialty Coatings; 4007 Lockridge Street, San Diego, CA 92102. Telephone 800-250-4519. Fax 619-262-8606. Website: www.westcoat.com.

2.02 MATERIALS

- A. As basis of design Westcoat ALX Pro Solar Reflective Finish System (no substitutions will be accepted): Waterproof walking deck system that is reinforced with metal lath and installed with a series of three separate polymer-modified cementitious applications, and sealed with acrylic topcoat.

2.03 COMPONENTS

- A. ALX Pro Solar Reflective Finish System: Waterproof walking deck system for use over plywood substrates, IAPMO ER-587.
 1. Sheet Membrane: WP-40 Sheet Membrane 6 inch by 75 feet for plywood seams, or 36 inch by 75 feet for complete plywood coverage.
 2. Metal Lath: WP-25 Metal Lath 2.5 pounds per square yard hot dipped galvanized.
 3. Staples: Minimum 1 inch crown by $\frac{5}{8}$ inch long, 16 gauge non-corrosive Senco P10 or equal.
 4. Base Coat: Combine one 50 pound bag of TC-1W White Base Coat Cement, 1¼ gallons of WP-81 Cement Modifier, and up to 1 quart of water. Apply by trowel at 40 square feet per batch.
 5. Fiberlath Resin Membrane: WP-47 Fiberlath applied over the entire deck. Combine one bag of TC-1W White Basecoat Coat Cement with five gallons of WP-90 Waterproofing Resin. Pour the mixture into the WP- 47, trowel thin and smooth at the coverage rate of approximately 250 square feet per batch
 6. Slurry Coat: Combine one 50 pound bag of TC-1W White Base Coat Cement, 1 gallon of WP-81 Cement Modifier, and up to ½ gallon of water. Apply by trowel at 100-150 square feet per batch.
 7. Texture Coat: Combine one 50 pound bag of TC-2 Smooth Texture Cement, 1 gallon of WP-81 Cement Modifier, and up to ½ gallon of water. Texture can be sprayed, troweled or broomed at a rate of about 150 to 300 square feet per batch.
 8. Topcoat: Apply desired color of SC-10 Solar Reflective Acrylic Topcoat in two thin applications at 200-300 square feet per gallon.

2.04 ACCESSORIES

- A. Supplemental Materials:
 1. Flashing shall be minimum 26 gauge bonderized sheet metal. 4 inch by 6 inch at wall to deck juncture and 2 inch by 4 inch drip edge at outside perimeter of deck.
 2. Drains shall be WP-35 ALX Deck Drain available through Thunderbird.
 3. Sealant shall be Westcoat WP-51 Polyurethane Sealant.
 4. WP-40 36 inch Sheet Membrane can also be installed to the entire deck when maximum protection is required and when a Class I Vapor Retarder is required.
 5. Westcoat Slope Technique may be used when additional sloping is required. Slope Technique should be applied after the Base Coat, prior to the Slurry Coat.
 6. Westcoat WP Wrap can be used to provide additional waterproofing with reinforcement, along the perimeter of decks, over flashing and other challenging areas.

7. WP-43 Sheet Membrane Primer may be used increased adhesion of the WP-40 Sheet Membrane is required.
8. WP-82 Cement Modifier Low Odor can be used in lieu of WP-81, when a lower odor option is required.
9. CA-29 Mini Safe Grip, CA-30 Small Safe Grip or CA-31 Large Safe Grip can be added to the SC-10 Acrylic Topcoat for added skid resistance.

PART 3 EXECUTION

3.01 EXAMINATION

- A. Verification of conditions.
 1. Inspect all surfaces to receive the pedestrian traffic system. Verify that surfaces are dry, clean, and free of contaminants that would prevent coating system from properly adhering to the surface.
 2. Verify that substrates have ¼ inch slope per linear foot.
 3. Before starting work, report in writing to the owner any unsatisfactory conditions.

3.02 SURFACE PREPARATION

- A. General:
 1. Prepare surfaces using methods recommended by the manufacturer for achieving the best result for the substrate under the project conditions.
- B. Plywood substrate:
 1. Provide minimum 5/8 inch exterior grade plywood.
 2. Plywood shall have a maximum joist span of 16 inches.
 3. Deflection should be less than L/360.

3.03 INSTALLATION

- A. Install coatings in accordance with manufacturer's instructions.
- B. Mix all materials in accordance with manufacturer's instructions.
- C. Use application equipment, tools, and techniques in accordance with manufacturer's instructions.
- D. Uniformly apply coatings at spread rates and in number of coats to achieve specified coverage.
- E. Adhere to all limitations, instructions, and cautions for pedestrian coatings as stated in the manufacturer's published literature.

3.04 FIELD QUALITY CONTROL

- A. Verify coatings and other materials are as specified.
- B. Verify coverages and finish of the system as work progresses.
- C. Manufacturer's representative shall provide technical assistance and guidance for surface preparation and application of coating systems.

3.05 PROTECTION AND CLEAN-UP

- A. Installation areas must be kept free from traffic and other trades during the application procedure and cure time.
- B. Protect finished surfaces of coating system from damage during construction.
- C. Touch-up, repair or replace damaged coating system after substantial completion.
- D. Clean area and remove all debris upon completion of work. Dispose of empty containers properly according to current Local, State and Federal regulations.
- E. Allow material to cure 4 to 6 hours before light pedestrian traffic is permitted, 24 hours before heavy traffic and an additional 48 hours before heavy objects are placed on the surface.

3.06 MAINTENANCE

- A. Contractor shall provide to owner, maintenance and cleaning instructions for the waterproof decking system upon completion of work. Owner is required to clean and maintain the surfaces to maintain manufacturer's warranty.

END OF SECTION

This guide specification has been prepared by Westcoat Specialty Coating Systems to assist design professionals in developing a project specific specification. This guide is a template that must be reviewed and adapted by specifiers to comply with project requirements. This guide specification is not to be copied directly into a project specification manual without review.

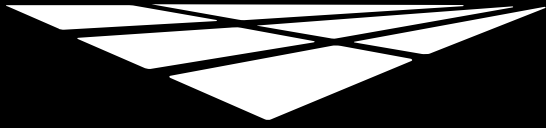

westcoat®

EVALUATION REPORT



WESTCOAT
4007 Lockridge Street
San Diego, CA 92102
(800) 250-4519
www.westcoat.com

WESTCOAT ALX STANDARD, ALX CUSTOM, ALX PRO STANDARD, ALX PRO CUSTOM, AND MACOAT SYSTEMS

CSI Sections:

- 07 18 13 Pedestrian Traffic Coatings**
- 07 30 05 Roofing Felt and Underlayment**

1.0 RECOGNITION

The Westcoat ALX Standard, ALX Custom, ALX Pro Standard, ALX Pro Custom, and MACoat Systems recognized in this report have been evaluated for use as walking deck and roof covering systems. The durability, roof fire classification, fire-resistance-rating, and wind uplift resistance properties of the Westcoat ALX Standard, ALX Custom, ALX Pro Standard, ALX Pro Custom, and MACoat Systems comply with the intent of the provisions of the following codes and regulations:

- 2021, 2018, 2015, 2012, and 2009 International Building Code® (IBC)
- 2021, 2018, 2015, 2012, and 2009 International Residential Code® (IRC)
- 2019 California Building Code (CBC) – attached Supplement
- 2019 California Residential Code (CRC) – attached Supplement
- 2020 City of Los Angeles Building Code (LABC) – attached Supplement
- 2020 City of Los Angeles Residential Code (LARC) – attached Supplement

2.0 LIMITATIONS

Use of the Westcoat ALX Standard, ALX Custom, ALX Pro Standard, ALX Pro Custom, and MACoat Systems recognized in this report is subject to the following limitations:

2.1 The Westcoat ALX Standard, ALX Custom, ALX Pro Standard, ALX Pro Custom, and MACoat Systems shall be manufactured, identified, and installed in accordance with this report and the applicable code. In case of a conflict, the more restrictive governs.

2.2 The Westcoat ALX Standard, ALX Custom, ALX Pro Standard, ALX Pro Custom, and MACoat Systems shall be

installed on slopes not less than ¼-inch per foot (2-percent slope).

2.3 The supporting structure shall be designed to support the loads and is outside the purview of this report.

2.4 Connection of deck perimeter flashing to substrates shall be designed to meet all applicable code requirements.

2.5 The use of the MACoat System over plywood for fire-resistance ratings is outside the purview of this report.

2.6 Installation of WP-40 Sheet Membrane, when used as an ice barrier, is limited to roof slopes of 2:12 (16.67 percent) and greater. When used as a component of the Westcoat ALX Standard, ALX Custom, ALX Pro Standard, and ALX Pro Custom Systems, the slope shall comply with Sections 2.2 and 3.2 of this report.

2.7 Installation of the WP-40 Sheet Membrane with roof coverings shall be mechanically fastened through the underlayments to the sheathing or rafters, and when used as a component of the Westcoat ALX Standard, ALX Custom, ALX Pro Standard, and ALX Pro Custom Systems as described in this report.

2.8 Installation of the WP-40 Sheet Membrane is limited to roof with attics or rafter spaces that are ventilated and comply with the requirements of the applicable code.

2.9 The Westcoat ALX Standard, ALX Custom, ALX Pro Standard, ALX Pro Custom, and MACoat Systems are manufactured in San Diego, CA.

3.0 PRODUCT USE

3.1 General: The Westcoat ALX Standard, ALX Custom, ALX Pro Standard, and ALX Pro Custom Systems recognized in this report are cementitious walking deck and roof covering systems used directly over plywood and the MACoat System is used directly over concrete substrates.

3.1.1 The WP-40 Sheet Membrane is a self-adhering reinforced modified bituminous membrane used as an alternative to an ice barrier as required in Chapter 15 of the IBC or Chapter 9 of the IRC. The WP-40 Sheet Membrane, when used with the Westcoat ALX Standard, ALX Custom, ALX Pro Standard, ALX Pro Custom systems, complies with the requirements of Acceptance Criteria for Self-Adhered Roof Underlayments for Use as an Ice Barrier (AC48) and Acceptance Criteria for Roof Underlayments (AC188).

3.2 Fire Classification Roof Assemblies: The Westcoat ALX Standard, ALX Custom, ALX Pro Standard, ALX Pro Custom, and MACoat Systems are components of Class A roof assemblies when installed in accordance with this report at a minimum slope of ¼ :12 (2-percent slope).

The product described in this Uniform Evaluation Service (UES) Report has been evaluated as an alternative material, design or method of construction in order to satisfy and comply with the intent of the provision of the code, as noted in this report, and for at least equivalence to that prescribed in the code in quality, strength, effectiveness, fire resistance, durability and safety, as applicable, in accordance with IBC Section 104.11. This document shall only be reproduced in its entirety.





3.3 One-hour Fire-resistance-rated Floor(Roof)/Ceiling Assemblies:

3.3.1 ALX Standard and Custom Systems: The Westcoat ALX Standard and ALX Custom Systems, when installed in accordance with Section 3.5 of this report over minimum $\frac{5}{8}$ -inch-thick exterior-grade plywood, with nominal 2-by-8 solid sawn lumber joists spaced at 16 inches on center maximum with all plywood joints blocked, may be used in place of the double wood floor described in Construction 13 of 2021, 2018, 2015, and 2012 IBC Table 721.1(3) [2009 IBC Table 720.1(3)]. Ceiling construction shall comply with Item Numbers 13-1.1 to 13-1.4 of 2021, 2018, 2015, and 2012 IBC Table 721.1(3) [2009 IBC Table 720.1(3)].

3.3.2 ALX Pro Standard and Pro Custom Systems: The Westcoat ALX Pro Standard and Pro Custom systems, when installed in accordance with Section 3.5 of this report over minimum $\frac{5}{8}$ -inch-thick exterior-grade plywood, with nominal 2-by-10 solid sawn lumber joists spaced at 16 inches on center maximum with all plywood joints blocked, may be used in place of the double wood floor described in Construction 13 of 2021, 2018, 2015, and 2012 IBC Table 721.1(3) [2009 IBC Table 720.1(3)]. Ceiling construction shall comply with Item Numbers 13-1.1 to 13-1.4 of 2021, 2018, 2015, and 2012 IBC Table 721.1(3) [2009 IBC Table 720.1(3)].

3.4 Wind Resistance: Installation to plywood is limited on structures with a maximum height of 40 feet, for use in Exposure B areas subject to the following:

- a) A basic wind speed of 130 miles per hour under the 2021 IBC and 2018 IBC.
- b) A maximum design wind speed of 130 miles per hour under the 2021 IRC, 2018 IRC, 2015 IBC, 2015 IRC, and 2012 IBC.
- c) A maximum of 100 miles per hour nominal design 3-second-gust basic wind speed under the 2009 IBC and 2012 and 2009 IRC.

The maximum allowable wind loads are limited by the capacity of the deck construction. The decking shall be designed to withstand wind pressures in accordance with Section 1609.5.1 of the IBC or Section R301.2.1 of the IRC.

3.5 Installation:

3.5.1 Westcoat ALX Standard, ALX Custom, ALX Pro Standard, and ALX Pro Custom:

a) General: The Westcoat ALX Standard, ALX Custom, ALX Pro Standard, and ALX Pro Custom walking deck and roof covering systems shall be installed in accordance with this report, the manufacturer's published installation instructions, and the applicable code. In case of a conflict, the more restrictive governs.

The system shall be applied where an ambient and surface temperature range of 50°F to 90°F is available for 24 hours. Materials shall not be applied when subject to wet weather. Substrates and all coating surfaces shall be structurally sound, clean, and dry. The minimum finished deck slope shall be $\frac{1}{4}$ inch per 1 foot (2-percent slope). Additional installation details are shown in Table 1 of this report.

b) Plywood Substrates: Plywood substrates shall comply with Section 4.1.2 (k) of this report. All edges shall be blocked. Face plies shall be perpendicular to the supports. The plywood shall be attached to all blocking and end bearing framing with wood screws, screw- or ring-shank nails equivalent to 8d common nails. The plywood shall be installed at a maximum span of 16 inches on center. The plywood shall be dry, clean, and free of any foreign material such as oil, dust, grease, or paint.

c) WP-40 Sheet Membrane: The WP-40 Sheet Membrane complying with Section 4.1.2 (l) of this report shall be applied over all plywood joints in 6-inch-wide strips or may be applied over the entire deck with the sheet membrane roll measuring 36 inches by 75 feet.

d) Metal Lath: The WP-25 Metal Lath complying with Section 4.1.2 (i) of this report is applied perpendicular to plywood sheets. Metal lath shall be installed over metal flashing, stopping at least $\frac{1}{2}$ -inch from all deck edges or vertical juncture. The lath seams shall be staggered a minimum of 2 inches from any parallel plywood joints. Lath shall be lapped 1 to 2 inches at seams and stapled to the plywood every 1 to 2 inches. A minimum of 16 WP-10 Staples, complying with Section 4.1.2 (j) of this report, per square foot, are required to attach the lath to the plywood substrate.

e) Base Coat: The base coat mixture consists of one 50-pound bag of TC-1 Basecoat Cement complying with Section 4.1.2 (a), combined with $1\frac{1}{4}$ gallons of WP-81 Cement Modifier and up to 1 quart of water. This mixture yields a total of $4\frac{1}{2}$ gallons and shall be troweled over the horizontal metal lath surface at a rate of 40 ft² per mix, to a minimum 0.142 inch thickness. Prior to the application of the slurry coat, the base coat shall be allowed to cure firm.

f) Slurry Coat: The slurry coat is prepared by mixing one bag of TC-1 Basecoat Cement complying with Section 4.1.2 (a) of this report, 1 gallon of WP-81 Cement Modifier, and up to $\frac{1}{2}$ gallon of water. The mixture shall be troweled over the cured base coat at a rate of 100 to 150 ft² per mix, to a minimum of 0.063 inch thickness, and allowed to cure.

3.5.2 ALX Pro Standard and ALX Pro Custom Systems: As an option, to transition from ALX Standard and ALX Custom Systems to ALX Pro Standard and ALX Pro Custom Systems, the WP-47H lath shall be installed over the base coat described in Section 3.5.1 (e) and lapped over the seams at a minimum of 2 inches. The mix is prepared with 5 gallons



of WP-90 Waterproofing Resin and one bag of TC-1 Basecoat Cement complying with Section 4.1.2 (a) of this report. This mixture shall be troweled over the WP-47H at a rate of 225 to 250 ft² per mix. Use a brush to spread the mix on the flashing and into seams and corners. Allow the surface to dry for 1-4 hours at 70°F. Scrape off any high spots or ridges that may inhibit the application of a smooth texture coat. Trim any WP-47H that is showing on perimeters after the material has hardened.

3.5.3 ALX Standard and ALX Pro Standard Systems (Following installation in accordance with Section 3.5 of this report):

a) Texture Coat: The texture coat is prepared by mixing one bag of either TC-1 Basecoat Cement complying with Section 4.1.2 (a), TC-2 Smooth Texture Cement complying with Section 4.1.2 (b), TC-3 Medium Texture Cement complying with Section 4.1.2 (c), or TC-5 Grout Texture Cement complying with Section 4.1.2 (d) of this report with 1 gallon of WP-81 Cement Modifier, and up to ½ gallon of water. The texture coat can be troweled, sprayed, or broomed over the slurry coat at a rate of 150 to 200 ft² per mix, to a minimum 0.047 inch thickness over the slurry coat and be allowed to fully cure.

b) Topcoat: The SC-10 acrylic topcoat shall be applied over the texture coat to a minimum thickness of 6 mils dry, using a roller in a maximum of two applications at a rate of 125 ft²/gal total, or 200-300 ft²/gal per coat and be allowed to fully cure.

3.5.4 ALX Custom, ALX Pro Custom, and MACoat Custom Systems:

The following coating applications apply only to ALX Custom, ALX Pro Custom, and MACoat Custom Systems and shall comply with Section 3.5 of this report:

a) Grout Coat: The grout coat is prepared by mixing one bag of TC-5 Medium Texture Cement complying with Section 4.1.2 (d) of this report with 1 gallon of WP-81 Cement Modifier, and up to ½ gallon of water. The grout coat shall be troweled over the slurry coat at a rate of 100 to 150 ft² per mix, to a minimum 0.047-inch dry thickness over the slurry coat, and be allowed to fully cure before the application of the texture coat.

b) Texture Coat: The texture coat is prepared by mixing one bag of TC-2 Smooth Texture Cement complying with Section 4.1.2 (b) or TC-5 Medium Texture Cement complying with Section 4.1.2 (d) of this report, with 1 gallon of WP-81 Cement Modifier, and up to ½ gallon of water. The TC-40 Liquid Colorant may be added to a maximum of 4 ounces until the color is consistent. The texture coat shall be troweled, sprayed, or broomed over the grout coat at a rate of 150 to 200 ft² per mix, to a minimum 0.047-inch dry thickness over the grout coat, and be allowed to fully cure before the application of the stain.

c) SC-35 Water-Based Stain: The stain shall be applied at a rate of 200 to 400 ft²/gal using a pump sprayer, airless sprayer, HVLP sprayer, brush, or broom over the texture coat. The stain shall be allowed to fully dry before the application of the sealer.

d) SC-70 Acrylic Lacquer Sealer: The sealer shall be applied at a rate of 200 to 300 ft²/gal using a sprayer, brush, or roller over the stain. The sealer shall be allowed to fully dry.

3.5.5 MACoat System™:

a) General: The MACoat System™ walking deck and roof covering systems shall be installed in accordance with the manufacturer's published installation instructions, the applicable code, and this report. In the event of a conflict, the more restrictive governs.

The system shall be applied where an ambient and surface temperature range of 50°F to 90°F is available for 24 hours. Materials shall not be applied when subject to wet weather. Substrates and all coating surfaces shall be structurally sound, clean, and dry. The minimum finished deck slope shall be ¼:12 (2-percent slope). Additional installation details are shown in Table 2 of this report.

b) Concrete Substrates: Concrete substrates shall comply with Section 4.2.2 (h) of this report. Concrete surfaces shall be prepared to a profile equal to CSP 3 as specified by the International Concrete Repair Institute (ICRI). Concrete cracks greater than 1/32-inch width shall be routed out in a ¼-in by ¼-in, and WP-47A Seam Tape described in Section 4.2.2 (b) of this report shall be installed over all cracks and seams. EC-72 Epoxy Patch Gel shall be applied over the WP-47A tape and troweled with silica sand for adhesion of the coating. Concrete control joints shall comply with local building codes and comply with industry standards.

c) WP-47H FiberLath: The WP-47H complying with Section 4.2.2 (a) of this report is applied perpendicular to the deck, overlapping the seams at least 2 inches.

d) Base Coat: The Base Coat is prepared by mixing one bag of TC-1 Base Coat Cement with 5 gallons of WP-90 Waterproofing Resin complying with Section 4.2.2 (c) of this report. The mixture shall be troweled over the horizontal WP-47H Fiberlath Heavy Duty at a rate of 220 to 260 ft² per mix, to a minimum 0.057 inch thickness over concrete and lath, and all metal and concrete shall be completely covered, and surfaces shall be flat.

e) Slurry Coat: The slurry coat is prepared by mixing one bag of TC-1 Base Coat Cement with 5 gallons of WP-90 Waterproofing Resin complying with Section 4.2.2 (d) of this report. The mixture shall be troweled over the cured base coat surface at a rate of 250 to 320 ft² per mix, to a minimum of



0.072 inch thickness over the base coat, and be allowed to cure.

f) Texture Coat: For a custom finish option, please refer to Section 3.5.4 of this report. An optional Texture Coat is prepared by mixing 1 quart of water with 5 gallons of WP-90 Waterproofing Resin and one bag of TC-1 Base Coat Cement complying with Section 4.2.2 (c) of this report. The texture coat shall be troweled over and applied over the slurry coat at a rate of 300 to 350 ft² per mix, to a minimum 0.035 inch dry thickness over the slurry coat, and be allowed to fully cure before the application of the topcoat.

g) Topcoat: The SC-10 acrylic topcoat shall be applied over the texture coat to a minimum thickness of 6 mils dry, using a roller in a maximum of two applications at a rate of 125 ft²/gal total, or 200-300 ft²/gal per coat and be allowed to fully cure.

4.0 PRODUCT DESCRIPTION

4.1 Westcoat ALX Standard, ALX Custom, ALX Pro Standard, and ALX Pro Custom Systems

4.1.1 General: Westcoat ALX Standard, ALX Custom, ALX Pro Standard, and ALX Pro Custom Systems is a cementitious multi-layer protective coating system for use over plywood. The system consists of reinforcing metal lath, cementitious filler, waterproofing sheet membrane, and acrylic sealer.

4.1.2 Components:

a) TC-1 Basecoat Cement: The TC-1 is a portland cement mixture, dry-blended with silica sand and proprietary additives. TC-1 has a maximum shelf life of 1 year when stored in unopened 50-lb bags in dry locations out of direct sunlight at temperatures ranging from 40°F to 90°F.

b) TC-2 Smooth Texture Cement: The TC-2 is a portland cement mixture, dry-blended with silica sand and proprietary additives. TC-2 has a maximum shelf life of 1 year when stored in unopened 50-lb bags in dry locations out of direct sunlight at temperatures ranging from 40°F to 90°F.

c) TC-3 Medium Texture Cement: The TC-3 is a portland cement mixture, dry-blended with silica sand and proprietary additives. TC-3 has a maximum shelf life of 1 year when stored in unopened 50-lb bags in dry locations out of direct sunlight at temperatures ranging from 40°F to 90°F.

d) TC-5 Grout Texture Cement: The TC-5 is a portland cement mixture, dry-blended with silica sand and proprietary additives. TC-5 has a maximum shelf life of 1 year when stored in unopened 50-lb bags in dry locations out of direct sunlight at temperatures ranging from 40°F to 90°F.

e) TC-40 Liquid Colorant (Use with ALX Custom): The TC-40 is a water-based slurry, formulated with high pigment levels used to tint the TC-2 basecoat product described in Section 4.1.2 (b) of this report. TC-40 has a maximum shelf life of 1 year when stored in unopened 10-ounce bottles in dry locations out of direct sunlight at temperatures ranging from 50°F to 75°F.

f) SC-10 Acrylic Topcoat (Use with ALX Standard): The SC-10 is an acrylic water-based coating used as a topcoat. SC-10 has a shelf life of 2 years in unopened 1 or 5 gallon pails stored at temperatures ranging from 40°F to 100°F.

g) SC-35 Water-Based Stain(Use with ALX Custom): The SC-35 is an acrylic water-based color stain when applied to TC-2 Smooth Texture Cement described in Section 4.1.2 (b). SC-35 has a shelf life of 3 years when stored in unopened 1- or 5-gallon pails in dry locations.

h) SC-70 Acrylic Lacquer Sealer (Use with ALX Custom): The SC-70 is an acrylic lacquer sealer. SC-70 has a maximum shelf life of 5 years when stored in unopened 1- or 5-gallon pails in dry locations out of direct sunlight at temperatures ranging from 40°F to 100°F.

i) WP-25 Metal Lath: The metal lath shall be 2.5 pounds per square yard, in accordance with ASTM C847. The lath is delivered in rolls measuring 27 inches wide by 97 inches long.

j) WP-10 Staples: The staples shall comply with ASTM F1667 and shall have a minimum 5/8 inch long leg, a minimum 1-inch crown, and be formed from hot-dip galvanized, minimum No. 16 gauge.

k) Plywood: Plywood, with an exterior bond classification, conforming to DOC PS-1 or DOC PS-2, shall be a minimum 5/8-inch thick.

l) WP-40 Sheet Membrane: The WP-40 Sheet Membrane consists of a self-adhering reinforced modified bituminous membrane with a white-colored reflective topping applied to the top surface. The membrane is nominally 40-mil-thick (0.040 inch) and produced in rolls that are 6, 12, and 36-inches wide by 75 feet long.

m) WP-81 Cement Modifier: The WP-81 is an acrylic liquid modifier used with TC-1, TC-2, TC-3 and TC-5 described in Sections 4.1.2 items (a) through (d) of this report. WP-81 has a maximum shelf life of 2 years when stored in unopened 1- or 5-gallon pails in dry locations at temperatures ranging from 40°F to 100°F.

n) Permeability: The ALX and ALX Pro (Standard and Custom) Systems with full coverage of WP-40 Sheet Membrane, have a water vapor permeance rating of 0.1 perm or less when tested in accordance with ASTM E96 Procedure



Originally Issued: 03/29/2022

Revised: 03/22/2024

Valid Through: 03/31/2025

A (Desiccant Method) at 73.4°F and 50 percent relative humidity.

4.1.3 ALX Pro Standard and ALX Pro Custom Systems:

The ALX Pro Standard and ALX Pro Customs Systems shall use the following components in addition to the applicable items listed in Sections 4.1.2 (a) through (m) of this report:

a) WP-47H Fiberlath: The WP-47H is a fiberglass lath reinforcing mesh, nominal 0.020-inch thickness and nominal weight of 5.9 oz/yd². The lath is produced in rolls that are 38 inches wide by 150 feet long. The WP-47H has a reinforcing mesh warp of 5.4 per inch and 6 per inch west hurl leno weave.

b) WP-90 Waterproofing Resin: The WP-90 is an acrylic-polymer modified resin that can be used as an additive for TC-1 Basecoat Cement described in Section 4.1.2 (a) of this report. WP-90 has a maximum shelf life of 2 years when stored in unopened 1- or 5-gallon pails in dry locations at temperatures ranging from 40°F to 100°F.

c) Permeability: The ALX Pro Standard and ALX Pro Custom Systems have a water vapor permeance rating of 0.1 perm or less when tested in accordance with ASTM E96 Procedure A (Desiccant Method) at 73.4°F and 50 percent relative humidity.

4.2 MACoat System™

4.2.1 General: MACoat™ System is a cementitious multi-layer protective coating system for use over concrete. The system consists of reinforcing metal lath, cementitious filler, waterproofing sheet membrane, and acrylic sealer.

4.2.2 Components:

a) WP-47H Fiberlath: The WP-47H is a fiberglass lath reinforcing mesh, nominal 0.020-inch thickness and nominal weight of 5.9 oz/yd². The lath is produced in rolls that are 38 inches wide by 150 feet long. The WP-47H has a reinforcing mesh warp of 5.4 per inch and 6 per inch west hurl leno weave.

b) WP-47A Seam Tape: The WP-47A is a fiberlath tape that can be used to reinforce concrete cracks. The tape has a nominal 0.018-inch thickness and weight of 4.5 oz/yd². The tape is produced in rolls that are 3 inches wide by 100 feet long.

c) TC-1 Basecoat Cement: The TC-1 is a portland cement mixture, dry-blended with silica sand and proprietary additives. TC-1 has a maximum shelf life of 1 year when stored in unopened 50-lb bags in dry locations out of direct sunlight at temperatures ranging from 40°F to 90°F.

d) WP-90 Waterproofing Resin: The WP-90 is an acrylic-polymer modified resin that can be used as an additive for

TC-1 Basecoat Cement. WP-90 has a maximum shelf life of 2 years when stored in unopened 1- or 5-gallon pails in dry locations at temperatures ranging from 40°F to 100°F.

e) SC-10 Acrylic Topcoat: The SC-10 is an acrylic water-based coating used as a topcoat. SC-10 has a shelf life of 2 years in unopened 1- or 5-gallon pails stored at temperatures ranging from 40°F to 100°F.

f) WP-51 Polyurethane Sealant: The WP-51 sealant is used along with bonderized flashing, for sealing all seams and overlaps. The shelf life is one year in a 10-ounce and two years in 20-ounce unopened cartridges, respectively, and stored at temperatures ranging from 40°F to 100°F.

g) EC-72 Epoxy Patch Gel: The EC-72 gel is a two-component epoxy patching compound. The shelf is two years in ½- or 2-gallon unopened kits and stored at temperatures ranging from 40°F to 100°F.

h) Concrete: Concrete shall comply with the IBC or IRC as normalweight, with a minimum specified compressive strength, f_c' , of 2,500 psi and be a minimum of 2-inches thick.

5.0 IDENTIFICATION

Product packaging shall include the manufacturer's name (Westcoat), address, product name, shelf life, date of manufacture or batch/lot number, product name, and evaluation report number (ER-587). The product identification may also include either the IAPMO Uniform Evaluation Service Mark of Conformity (as shown below) or the IAPMO ER-587.

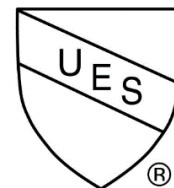

IAPMO UES ER-587

6.0 SUBSTANTIATING DATA

6.1 Data in accordance with ICC-ES AC39.

6.2 Data in accordance with the ICC-ES AC48.

6.3 Data in accordance with the ICC-ES AC188.

6.4 Reports of water vapor transmission testing in accordance with ASTM E96.

6.5 Test reports are from laboratories in compliance with ISO/IEC 17025.



7.0 STATEMENT OF RECOGNITION

This evaluation report describes the results of research completed by IAPMO Uniform Evaluation Service on Westcoat ALX Standard, ALX Custom, ALX Pro Standard, ALX Pro Custom, and MACoat Systems to assess conformance to the codes shown in Section 1.0 of this report

and serves as documentation of the product certification. Products are manufactured at locations noted in Section 2.9 of this report under a quality control program with periodic inspections under the supervision of IAPMO UES.

For additional information about this evaluation report please visit www.uniform-es.org or email us at info@uniform-es.org

TABLE 1: ALX SYSTEMS INSTALLATION DETAILS

SYSTEM	BASE COAT	INTERMEDIATE COAT	THIRD COAT	FOURTH COAT	FIFTH COAT	TOPCOAT
ALX STANDARD FINISH	TC-1 Basecoat Cement applied at 40 sq.ft. per bag mixture.	TC-1 Basecoat Cement applied at 100-150 sq.ft. per bag mixture.	TC-1, TC-2, TC-3, or TC-5 Cements applied at 100-150 sq.ft. per bag mixture.	-	-	SC-10 Acrylic Topcoat applied at a rate of 125 sq. ft. / gal.
ALX CUSTOM FINISH	TC-1 Basecoat Cement applied at 40 sq.ft. per bag mixture.	TC-1 Basecoat Cement applied at 100-150 sq.ft. per bag mixture.	TC-1 Basecoat Cement applied at 100-150 sq.ft. per bag mixture.	TC-5 Medium Texture Cement applied at 200 sq. ft. per bag mixture.	TC-2 or TC-5 Cements applied at 100-150 sq.ft. per bag mixture.	SC-70 Acrylic Lacquer applied at a rate of 200-300 sq. ft. / gal.
ALX PRO STANDARD FINISH	TC-1 Basecoat Cement applied at 40 sq.ft. per bag mixture.	TC-1 Basecoat Cement applied at 225-250 sq.ft. per bag mixture.	TC-1 Basecoat Cement applied at 100-150 sq.ft. per bag mixture.	TC-1, TC-2, TC-3 or TC-5 Cements applied at 100-150 sq.ft. per bag mixture.	-	SC-10 Acrylic Topcoat applied at a rate of 125 sq. ft. / gal.
ALX PRO CUSTOM FINISH	TC-1 Basecoat Cement applied at 40 sq.ft. per bag mixture.	TC-1 Basecoat Cement applied at 225-250 sq.ft. per bag mixture.	TC-1 Basecoat Cement applied at 100-150 sq.ft. per bag mixture.	TC-5 Medium Texture Cement applied at 200 sq. ft. per bag mixture.	TC-2 or TC-5 Cements applied at 100-150 sq.ft. per bag mixture.	SC-70 Acrylic Lacquer applied at a rate of 200-300 sq. ft. / gal.
ALX WATERPROOFING UNDERLAYMENT	TC-1 Basecoat Cement applied at 40 sq.ft. per bag mixture.	TC-1 Basecoat Cement applied at 100-150 sq.ft. per bag mixture.	-	-	-	-
ALX PRO WATERPROOFING UNDERLAYMENT	TC-1 Basecoat Cement applied at 40 sq.ft. per bag mixture.	TC-1 Basecoat Cement applied at 225-250 sq.ft. per bag mixture.	TC-1 Basecoat Cement applied at 100-150 sq.ft. per bag mixture.	-	-	-

Joist Span: All systems require a maximum joist span of 16-inches, except the ALX Waterproofing Underlayment and ALX Pro Waterproofing Underlayment. These systems require a maximum joist span of 12-inches.

Substrates: All systems require a minimum 5/8-inch exterior grade plywood, except the ALX Waterproofing Underlayment and ALX Pro Waterproofing Underlayment. These systems require 1-inch exterior grade plywood.

Deck Slope: All systems require ¼ : 12

Minimum Base Coat Thickness: 9/64-inch for all systems.

Sheet Membrane: 6-inch WP-40 Sheet Membrane is a minimum requirement for all systems, except full coverage of the 36-inch WP-40 Sheet Membrane is required for the ALX Waterproofing Underlayment and ALX Pro Waterproofing Underlayment.

TABLE 2: MACOAT SYSTEM INSTALLATION DETAILS

SYSTEM	BASE COAT	INTERMEDIATE COAT	OPTIONAL THIRD COAT	TOPCOAT
MACOAT STANDARD	TC-1 Basecoat Cement applied at 220-260 sq.ft. per bag mixture.	TC-1 Basecoat Cement applied at 250-320 sq.ft. per bag mixture.	TC-1 Basecoat Cement applied at 300-350 sq.ft. per bag mixture.	SC-10 Acrylic Topcoat applied at a rate of 125 sq. ft. / gal.

Substrate: All systems require 2,500 psi concrete that is at least 2-inches thick

Deck Slope: All systems require ¼:12

Min Base Coat Thickness: 0.057 inch



CALIFORNIA SUPPLEMENT

WESTCOAT

4007 Lockridge Street

San Diego, CA 92102

(800) 250-4519

www.westcoat.com

WESTOCOAT ALX STANDARD, ALX CUSTOM, ALX PRO STANDARD, ALX PRO CUSTOM, AND MACOAT SYSTEMS

CSI Sections:

07 18 13 Pedestrian Traffic Coatings

07 30 05 Roofing Felt and Underlayment

1.0 RECOGNITION

Westcoat ALX Standard, ALX Custom, ALX Pro Standard, and ALX Pro Custom and MaCoat Systems recognized in this report have been evaluated for use as walking deck and roof covering systems. The durability, wind uplift resistance, roof fire classification, and fire-resistance-rating properties of the Westcoat ALX Standard, ALX Custom, ALX Pro Standard, ALX Pro Custom, and MaCoat Systems comply with the intent of the provisions of the following codes and regulations:

- 2019 California Building Code (CBC)
- 2019 California Residential Code (CRC)

2.0 ADDITIONAL LIMITATIONS

2.1 The Westcoat ALX Standard, ALX Custom, ALX Pro Standard, ALX Pro Custom, and MaCoat Systems may be used as Class A roof covering systems in accordance with Sections 1505.2 of the CBC or R902.1 of the CRC.

2.2 Only the Westcoat ALX Standard, ALX Custom, ALX Pro Standard, ALX Pro Custom Systems have been evaluated for use in buildings located in a Fire Hazard Severity Zone within State Responsibility Areas or any Wildland-Urban Interface Fire Area in accordance with Chapter 7A of the CBC or Section R337 of the CRC. The Westcoat ALX Standard, ALX Custom, ALX Pro Standard, ALX Pro Custom Systems comply with the requirements when tested in accordance with ASTM E2632 and ASTM E2726.

2.3 This supplement expires concurrently with ER-587.

For additional information about this evaluation report please visit

www.uniform-es.org or email us at info@uniform-es.org



CITY OF LOS ANGELES SUPPLEMENT

WESTCOAT
4007 Lockridge Street
San Diego, CA 92102
(800) 250-4519
www.westcoat.com

WESTCOAT ALX STANDARD, ALX CUSTOM, ALX PRO STANDARD, ALX PRO CUSTOM AND MACOAT SYSTEMS

CSI Sections:

- 07 18 13 Pedestrian Traffic Coatings
- 07 30 05 Roofing Felt and Underlayment

1.0 RECOGNITION

Westcoat ALX Standard, ALX Custom, ALX Pro Standard, ALX Pro Custom, and MaCoat Systems described in ER-587, the California Supplement to ER-587, and this supplemental report have been evaluated for use as walking deck and roof covering systems. The durability, wind uplift resistance, roof fire classification, and fire-resistance-rating properties of the Westcoat ALX Standard, ALX Custom, ALX Pro Standard, and ALX Pro Custom and MaCoat Systems comply with the intent of the provisions of the following codes and regulations:

- 2020 City of Los Angeles Building Code (LABC)
- 2020 City of Los Angeles Residential Code (LARC)

2.0 LIMITATIONS

Use of The Westcoat ALX Standard, ALX Custom, ALX Pro Standard, ALX Pro Custom, and MaCoat Systems recognized in this supplement are subject to the following limitations in addition to the limitations in ER-587 and the California Supplement in ER-587:

2.1 The Westcoat ALX Standard, ALX Custom, ALX Pro Standard, ALX Pro Custom, and MaCoat Systems may be used as Class A roof covering systems in accordance with Sections 1505.2 of the 2020 LABC or R902.1 of the 2020 LARC.

2.2 The Westcoat ALX Standard, ALX Custom, ALX Pro Standard, ALX Pro Custom, and MaCoat Systems shall be installed on slopes not less than ¼ inch per foot (2-percent slope).

2.3 The supporting structure shall be designed to support the loads and is outside the purview of this report.

2.4 The Westcoat ALX Standard, ALX Custom, ALX Pro Standard, and ALX Pro Custom shall have a minimum substrate of 5/8-inch-thick exterior-grade plywood.

2.5 The Westcoat ALX Standard, ALX Custom, ALX Pro Standard, ALX Pro Custom, and MaCoat Systems shall comply with the LADBS Information Bulletin P/BC 2020-016 (Dwellings in High Wind Velocity Areas (HWA)).

2.6 This supplement expires concurrently with ER-587.

For additional information about this evaluation report please visit www.uniform-es.org or email us at info@uniform-es.org

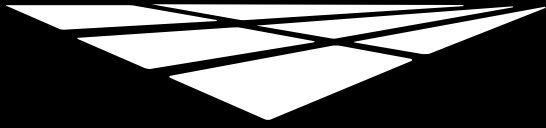

westcoat®

COLOR CHART

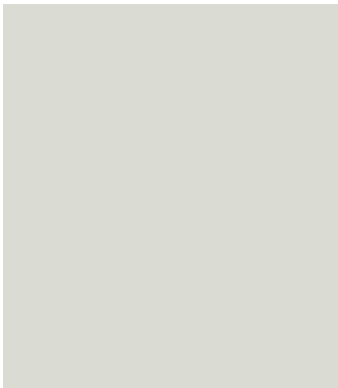

SR Gray | 101
SRI Value 84
CRRC Prod. ID#1316-0001

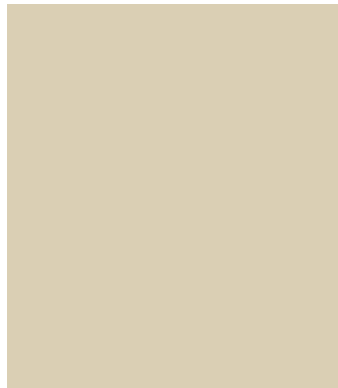

SR Tan | 100
SRI Value 91
CRRC Prod. ID#1316-0002

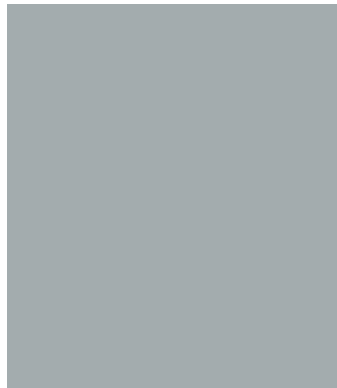

Heather Gray | 103
SRI Value 63

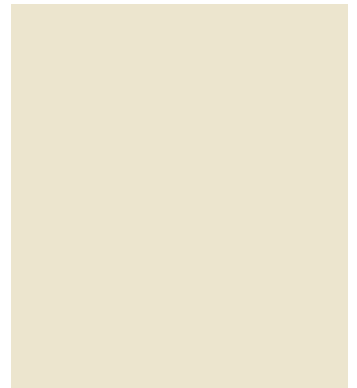

Canvas | 111
SRI Value 84

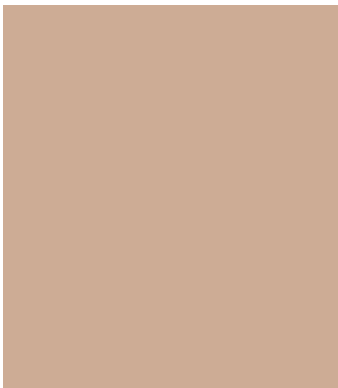

Salmon | 108
SRI Value 72

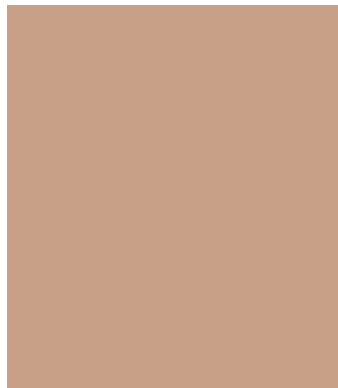

Coral | 106
SRI Value 66



Butterscotch | 105
SRI Value 84

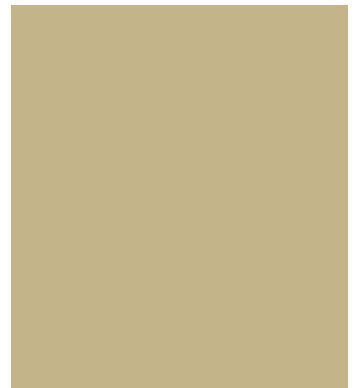

Coconut | 110
SRI Value 71



Powder Blue | 104
SRI Value 77

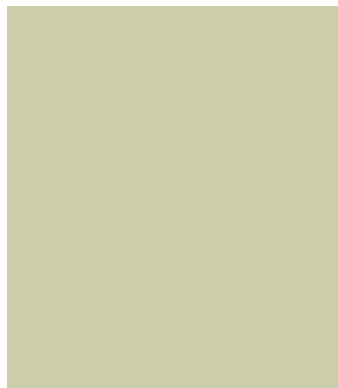

Seaside | 107
SRI Value 73

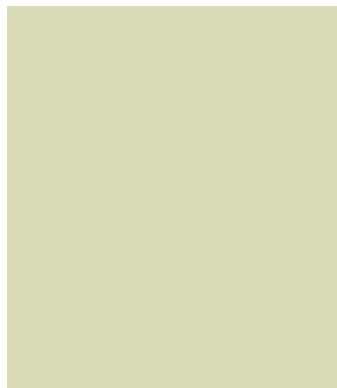

Lime | 109
SRI Value 78

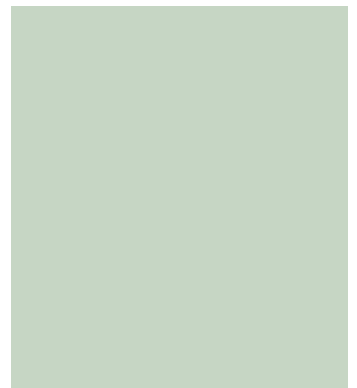

Winter Mint | 102
SRI Value 79

SR Gray and SR Tan meet the Cool Roof requirements of California Title 24, when installed per Westcoat's Solar Reflective System specifications.

Refer to the SC-10 Acrylic Topcoat Product Specification Sheet for SRI Value test data. See SC-10 Topcoat color chart online for more information, colors and lead time.



CAUTION:

Color will vary between products and sheens. This chart is for reference only. Please request an actual color sample or apply sample on site before beginning any project.





SR Series	Availability
SR Tan 100	Stock
SR Gray 101	Stock
Winter Mint 102	Made To Order
Heather Gray 103	Stock
Powder Blue 104	Made To Order
Butterscotch 105	Made To Order
Coral 106	Made To Order
Seaside 107	Made To Order
Salmon 108	Made To Order
Lime 109	Made To Order
Coconut 110	Made To Order
Canvas 111	Made To Order

Lead times based on 1, 1.5, and 2 gallon units

Stock = 2 day lead time | Made To Order = 10 day lead time

Extended manufacturing time may apply to larger volume orders.

Custom Colors available with color matching fee, minimum order and extended manufacturing time.



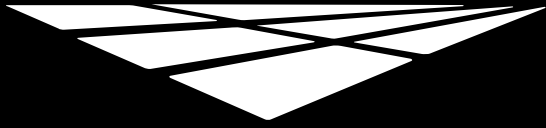

westcoat®

SAMPLE WARRANTY



WARRANTY

WESTCOAT ALX PRO SOLAR REFLECTIVE SYSTEM MATERIAL WARRANTY

Subject to the conditions, limitations and requirements set forth below, Westcoat warrants the Westcoat ALX materials to be free of defects in the material for a period of five (5) years from the date of original purchase of the materials provided that the materials are installed by a factory trained state-licensed contractor enrolled in the Westcoat QCA program and subject to all terms and conditions set forth below. Westcoat disclaims any warranty for the labor or installation of the ALX materials.

If the Westcoat ALX materials fail due to defects within the warranty period, Westcoat, in its sole discretion, will either provide replacement materials for the defective ALX materials or reimburse the original purchaser in an amount not to exceed the original cost of the materials. Westcoat shall in no way be responsible or liable for any labor costs or any incidental or consequential damages, including without limitation, economic losses, lost profits, business interruption, loss of use, contribution, indemnity or other losses arising from the use of the ALX materials.

This warranty is limited to the original purchases and is non-transferable. This warranty is void if the ALX materials are: applied to the top of OSB; not properly maintained; not installed pursuant to the current system information sheet; and/or applied at any area that is not built in accordance with applicable building codes. The warranty is also void if all of the materials are not purchased from an authorized distributor of Westcoat.

This warranty does not apply to and Westcoat has no responsibility or liability for: (1) the condition or movement of the substrate; (2) parts, products, or accessories not sold by Westcoat such as sheet metal flashings, scuppers and drains; (3) the loss of gloss, fading or cleaning; (4) repairs and/or maintenance of the sealer and texture coat (5) the application of its materials over an oriented strand board ("OSB") substrate; (6) abuse or misuse of the materials; or (7) improper installation.

THIS MATERIAL WARRANTY AND THE REMEDIES PROVIDED HEREUNDER ARE EXCLUSIVE AND GIVEN IN LIEU OF ALL OTHER WARRANTIES (WHETHER WRITTEN, ORAL, IMPLIED OR STATUTORY). THERE ARE NO OTHER WARRANTIES, EITHER EXPRESSED OR IMPLIED, INCLUDING BUT NOT LIMITED TO, WARRANTIES OF MERCHANTABILITY AND FITNESS FOR A PARTICULAR PURPOSE, THAT EXTEND BEYOND THAT SPECIFICALLY DESCRIBED HEREIN. PURCHASER'S SOLE AND EXCLUSIVE REMEDY AGAINST THE MANUFACTURERS OF WESTCOAT, INCLUDING CLAIMS BASED UPON THE MANUFACTURER'S NEGLIGENCE OR STRICT LIABILITY, SHALL BE LIMITED SOLELY TO THE REPLACEMENT OF ANY DEFECTIVE ALX MATERIAL OR A PAYMENT BY THE MANUFACTURER IN AN AMOUNT EQUAL TO THE COST OF THE ORIGINAL ALX MATERIAL.

The Westcoat ALX system requires a maintenance topcoat with WESTCOAT ACRYLIC TOPCOAT (or Westcoat Sealer) specified by a factory representative, every three to five years (depending on ultraviolet exposure and/or traffic) as determined by a Westcoat QCA OR authorized inspector. Inspections are required one year after installation and every two years thereafter by a Westcoat QCA or an authorized inspector. The record of the inspection must be kept in writing and entitlement to the benefits of this warranty require the purchaser to show proof of purchase of the materials and the record of inspection(s).

All claims arising from any defect in the ALX materials or under this Warranty shall be made, in writing, to Westcoat within ninety (90) days of the discovery of the alleged defect and within the time period of this warranty. Upon notification, Westcoat shall have the right to inspect and determine course of repair. The absence of a written claim within this time period shall constitute a waiver of all claims, rights and damages against Westcoat, and its affiliates. This warranty shall not toll or extend any statute of limitation applicable to a claim of negligence, breach of contract or strict liability against Westcoat.

Any and all disputes, claims or damages arising out of the use of ALX materials or this Warranty shall be arbitrated in the County of San Diego, State of California, utilizing the services of a neutral dispute resolution service upon which the purchaser and Westcoat agree, or if they cannot agree, utilizing the services of the American Arbitration Association. The purchaser and Westcoat hereby waive any right they may have to have a jury decide any dispute.



westcoat

4007 Lockridge Street San Diego, CA 92102
800•250•4519 • Fax 619•262•8606 • westcoat.com

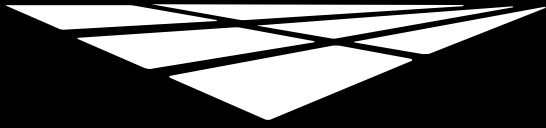

westcoat®

GENERAL MAINTENANCE



EXTERIOR COATINGS

Westcoat exterior coating systems (including systems such as ALX, ALX Pro, MACoat, Texture-Crete, etc.) offer durable, high-performance, long lasting surfaces that are designed to provide years of service against normal wear and usage. To extend the service life of your Westcoat system, it is recommended to implement a routine cleaning regimen and have periodic deck inspections. This information is a basic guideline only.

Routine Cleaning

All coating systems require maintenance and upkeep to ensure continued performance and to maximize the life of the system. Maintenance methods may vary depending on the system, texture, topcoat or sealer, environment conditions, slope, drainage, volume and type of traffic, and use of space.

Ensure that the coating surface is free from debris such as sand, gravel, metals, or other abrasives that can result in premature wear of the topcoat or sealer. Grease, oils, and other contaminants should be removed regularly to maintain the surface.

Be sure to test all cleaning agents in an unnoticeable area to ensure compatibility. Refer to the manufacturer's instructions and dilution rates for all cleaning agents. Routine cleaning can be achieved by using a mild cleaning solution such as "Simple Green" or mild soap. Utilize a brush or broom to help agitate and loosen up dirt and debris. Ensure that the surface is thorinsed with clean water thoroughly. Do not allow cleaning agents to dry on the surface.

A low psi pressure washer (do not exceed 1000 psi) equipped with fan tip and/or a soft bristle floor scrubber brush on a floor machine may be used to help aid in cleaning. Do not use metal-based or coarse brushes as they may damage the surface.

To remove water stains from calcium or lime build up, 100 grain vinegar can be used. Start by diluting the vinegar, eight parts water to one part vinegar. If needed, you can use the vinegar diluted one to one with water. Avoid using neat or full strength 100 grain vinegar. Scrub the diluted vinegar mixture over the surface. Be sure to completely rinse any residue thoroughly with clean water. Avoid using vinegar mixture or any cleaner in direct sunlight, as direct sun may evaporate cleaning solution and may leave a film or residue on the surface.

Any information provided by Westcoat Specialty Coating Systems is for general purposes only. Nothing presented by Westcoat Specialty Coating Systems constitutes design advice or a recommendation specific to a particular situation. Westcoat Specialty Coating Systems directs you to consult with the appropriate qualified design professional to ensure any product or information meets the requirements for the specific intended use, and complies with all building plans, specifications, codes or regulations. Westcoat Specialty Coating Systems expressly and specifically disclaims responsibility for any damages arising from the use of any information, and each recipient of this information agrees that there is no express or implied warranty, including any implied warranty of merchantability or fitness for a particular purpose, arising from any information provided by Westcoat Specialty Coating Systems.





EXTERIOR COATINGS

Maintenance and Inspections

All exterior coating systems should be periodically inspected and regularly maintained by a Westcoat Qualified Contractor Applicator (QCA). Inspections are required one year after installation and every two years thereafter by a factory authorized representative. After 3-5 years, a "reseal" (thorough cleaning and reapplication of Westcoat topcoat/sealer) may be required. Existing sealer or coating should be lightly abraded before application of topcoat or sealer. Some topcoats and sealers may require additional preparation, prior to recoating. Should damage occur, be sure to contact the original Westcoat applicator to inspect and repair the coating system immediately.

Best Practices

- Do not expose the coating surface to traffic, moisture, or chemical agents until the system is fully cured.
- Outdoor carpet or other matting materials are not recommended, as they may trap moisture, contribute to mildew, mold, and may damage the topcoat or sealer.
- Potted plants and/or planter boxes should be elevated off the surface and moved monthly to allow the coating to dry properly. Planter drainage may cause staining due to fertilizers and growing mediums. Drip pans or saucers should be utilized.
- Outdoor furniture should have coasters or pads to prevent indentations and damage to the coating.
- If barbecues are to be used, it is recommended to place a protective pan down to prevent damage from hot grease or coals.
- Do not cut, slice, or puncture the coating system. This is especially true for all waterproofing systems, such as ALX, ALX Pro, and MACoat.
- Avoid dragging bulky metal, concrete, or other types of objects over the surface.
- Fire pits are not recommended for use with Westcoat coating systems.
- Do not expose the coating system to solvents, harsh chemicals, or acids.
- Avoid subjecting the coating system to repeated heavy rolling loads.
- Tape or other adhesives should not be applied to finished surfaces.

Any information provided by Westcoat Specialty Coating Systems is for general purposes only. Nothing presented by Westcoat Specialty Coating Systems constitutes design advice or a recommendation specific to a particular situation. Westcoat Specialty Coating Systems directs you to consult with the appropriate qualified design professional to ensure any product or information meets the requirements for the specific intended use, and complies with all building plans, specifications, codes or regulations. Westcoat Specialty Coating Systems expressly and specifically disclaims responsibility for any damages arising from the use of any information, and each recipient of this information agrees that there is no express or implied warranty, including any implied warranty of merchantability or fitness for a particular purpose, arising from any information provided by Westcoat Specialty Coating Systems.

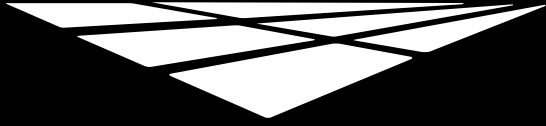

westcoat®

ARCHITECTURAL DETAILS

WESTCOAT MULTIPLE FLASHING DETAILS

NOT TO SCALE

NOTES:

- APPLY WP-51 ON ALL FLASHING SEAMS AND OVERLAPS. STANDARD OVERLAP IS BOTTOM TO TOP WITH A 4" OVERLAP.
- 2500 PSI MINIMUM FOR CONCRETE SUBSTRATES
- $\frac{5}{8}$ " EXTERIOR GRADE MINIMUM FOR PLYWOOD SUBSTRATE
- $\frac{1}{4}$ " MINIMUM SLOPE REQUIRED ON ALL DECKS
- REFER TO LOCAL BUILDING CODES & STANDARDS

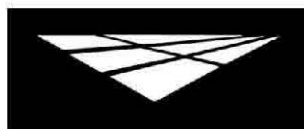
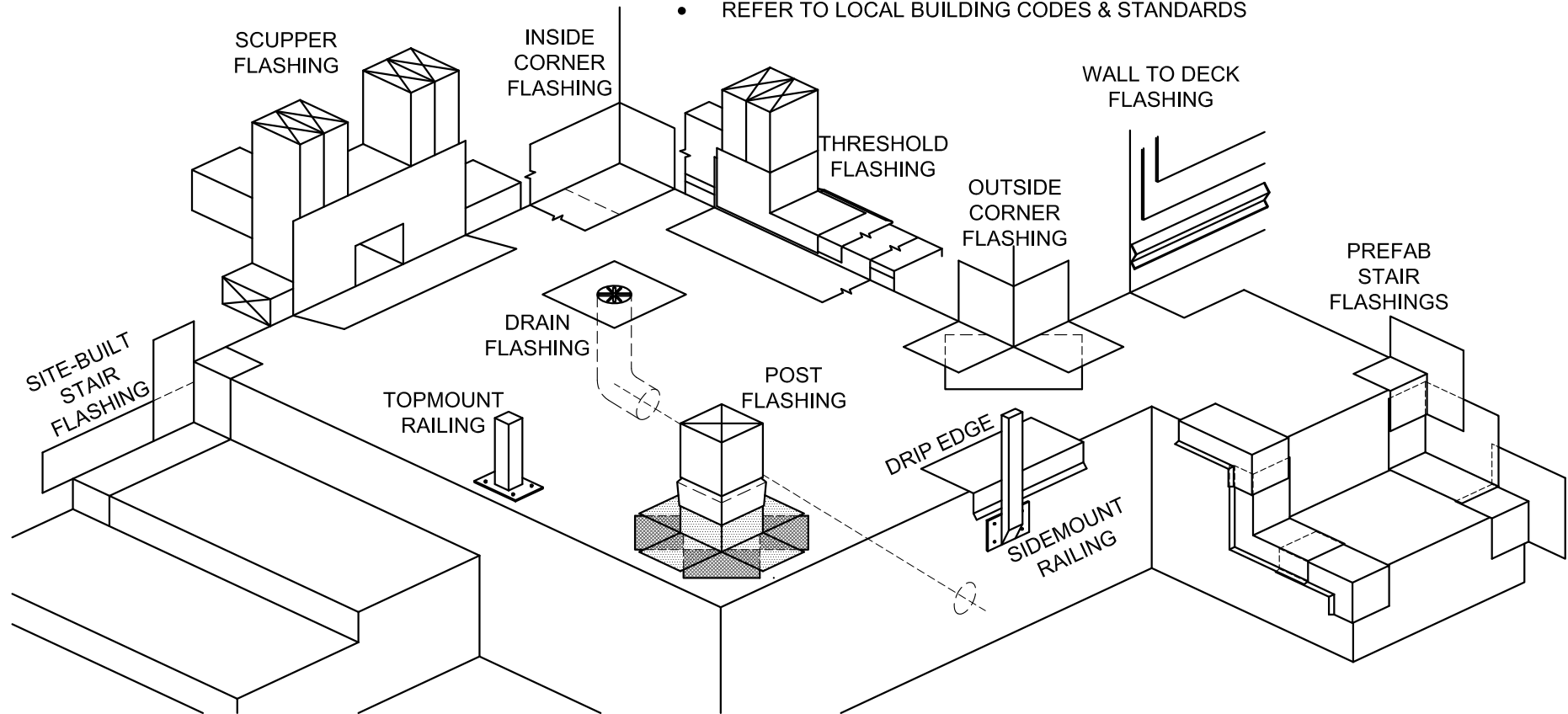

westcoat

800-250-4519
4007 LOCKRIDGE STREET

www.westcoat.com
SAN DIEGO, CA. 92102

WESTCOAT STAIR FLASHING DETAIL

NOT TO SCALE

NOTES:

- APPLY WP-51 ON ALL FLASHING SEAMS AND OVERLAPS. STANDARD OVERLAP IS BOTTOM TO TOP WITH A 4" OVERLAP.
- 2500 PSI MINIMUM FOR CONCRETE SUBSTRATES
- $\frac{5}{8}$ " EXTERIOR GRADE MINIMUM FOR PLYWOOD SUBSTRATE
- $\frac{1}{4}$ " MINIMUM SLOPE REQUIRED ON ALL DECKS
- REFER TO LOCAL BUILDING CODES & STANDARDS

PREFAB PIECES (INSIDE STAIRS)

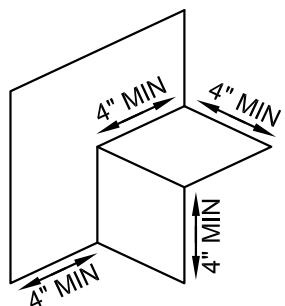

WP-270
SEALANT

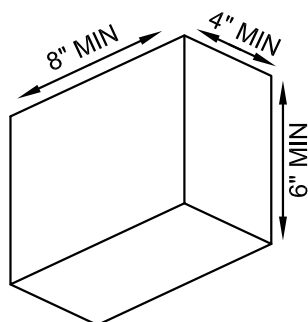

WP-271
SEALANT

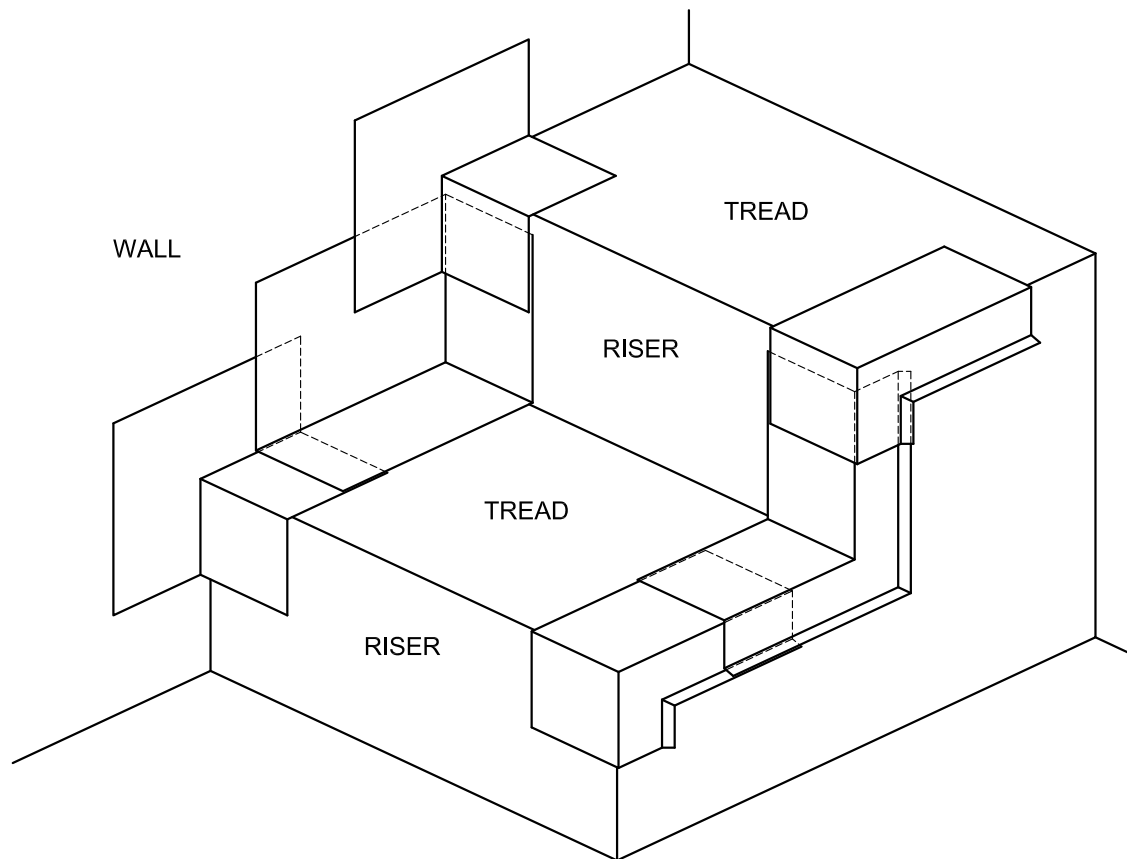

PREFAB PIECES (OUTSIDE STAIRS)

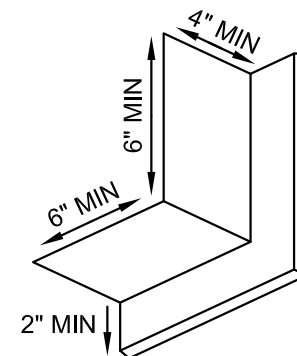

WP-281
SEALANT

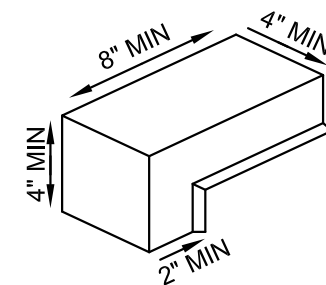

WP-280
SEALANT

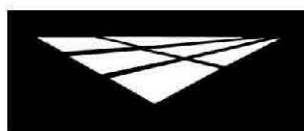

westcoat

800-250-4519
4007 LOCKRIDGE STREET

www.westcoat.com
SAN DIEGO, CA. 92102

WESTCOAT SCUPPER FLASHING DETAIL

NOT TO SCALE

NOTES:

- APPLY WP-51 ON ALL FLASHING SEAMS AND OVERLAPS. STANDARD OVERLAP IS BOTTOM TO TOP WITH A 4" OVERLAP.
- 2500 PSI MINIMUM FOR CONCRETE SUBSTRATES
- $\frac{5}{8}$ " EXTERIOR GRADE MINIMUM FOR PLYWOOD SUBSTRATE
- $\frac{1}{4}$ " MINIMUM SLOPE REQUIRED ON ALL DECKS
- REFER TO LOCAL BUILDING CODES & STANDARDS

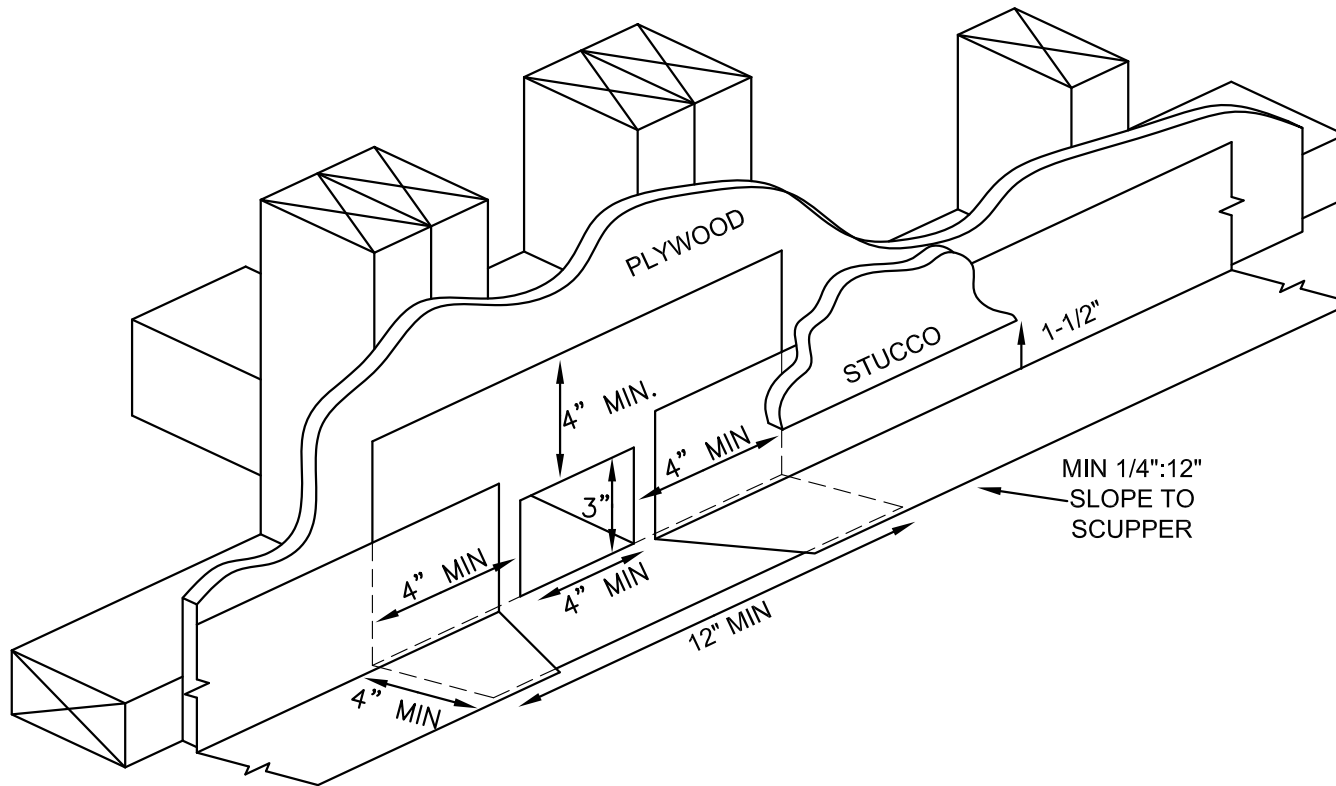

SITE-BUILT PIECES

(RIGHT)

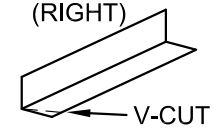

(LEFT)

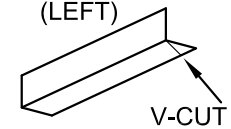

PREFABRICATED
SCUPPER FLASHING
WITH WP-30

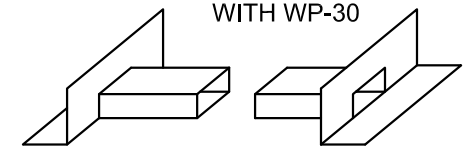

BACK

FRONT

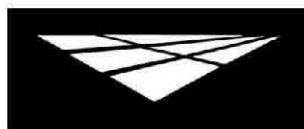

westcoat

800-250-4519
4007 LOCKRIDGE STREET

www.westcoat.com
SAN DIEGO, CA. 92102

WESTCOAT STAIR FLASHING DETAIL

NOT TO SCALE

NOTES:

- APPLY WP-51 ON ALL FLASHING SEAMS AND OVERLAPS. STANDARD OVERLAP IS BOTTOM TO TOP WITH A 4" OVERLAP.
- 2500 PSI MINIMUM FOR CONCRETE SUBSTRATES
- $\frac{5}{8}$ " EXTERIOR GRADE MINIMUM FOR PLYWOOD SUBSTRATE
- $\frac{1}{4}$ " MINIMUM SLOPE REQUIRED ON ALL DECKS
- REFER TO LOCAL BUILDING CODES & STANDARDS

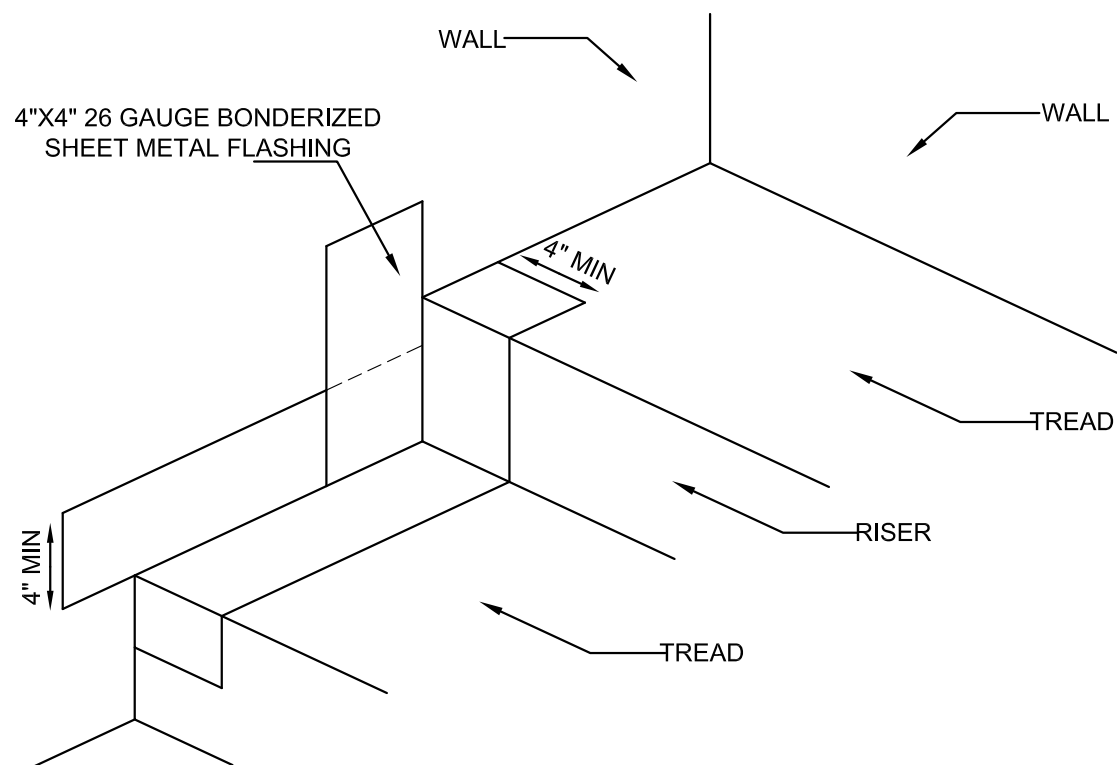

SITE BUILT PIECE

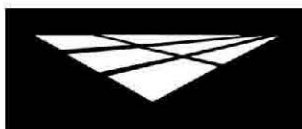
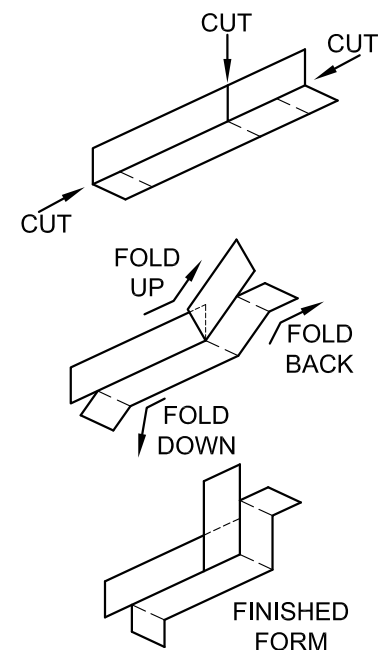

westcoat

800-250-4519
4007 LOCKRIDGE STREET

www.westcoat.com
SAN DIEGO, CA. 92102

WESTCOAT THRESHOLD FLASHING DETAIL

NOT TO SCALE

NOTES:

- APPLY WP-51 ON ALL FLASHING SEAMS AND OVERLAPS. STD. OVERLAP IS BOTTOM TO TOP WITH A 4" OVERLAP.
- 2500 PSI MINIMUM FOR CONCRETE SUBSTRATES
- 3/4" EXTERIOR GRADE MINIMUM FOR PLYWD. SUBSTRATE
- 1/4" MINIMUM SLOPE REQUIRED ON ALL DECKS
- REFER TO LOCAL BUILDING CODES & STANDARDS

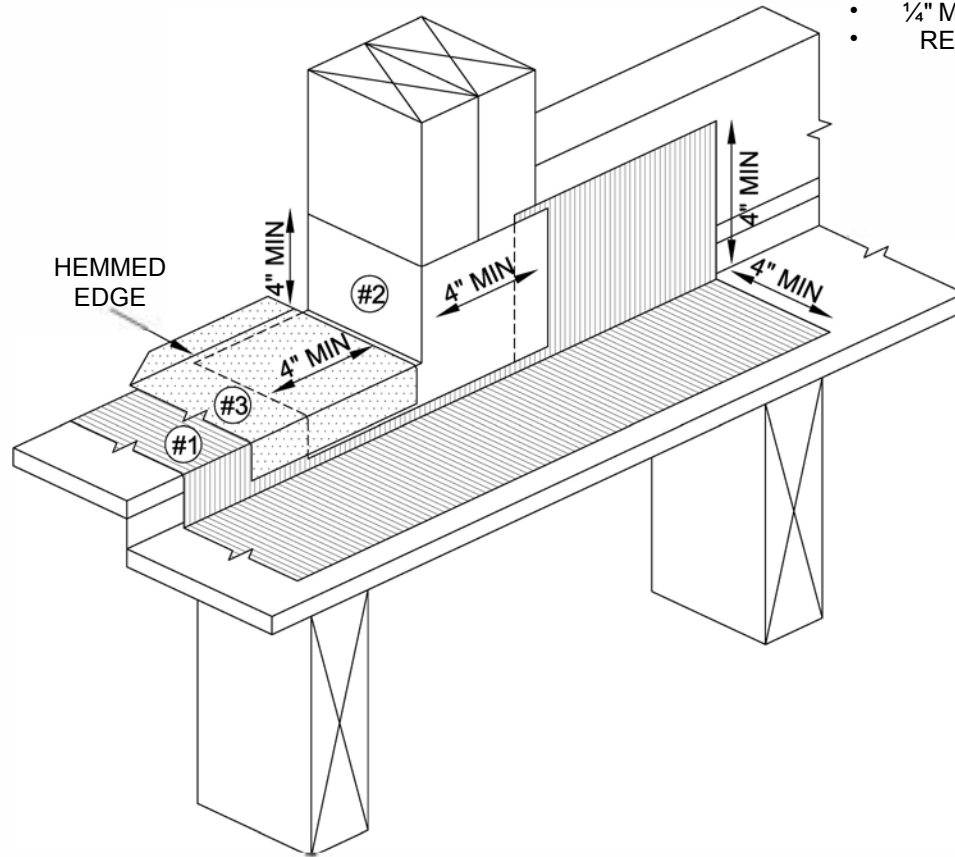

SITE BUILT PIECE

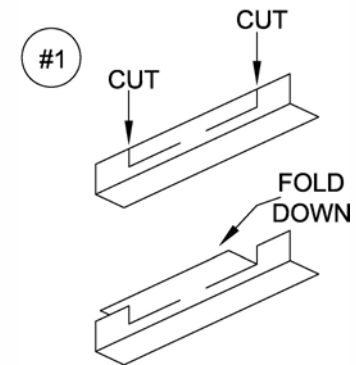

PREFAB. PIECES

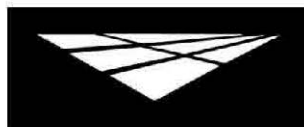
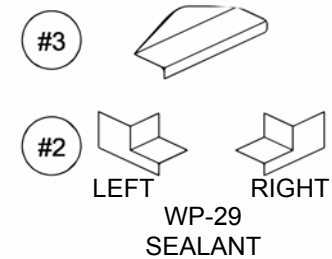

westcoat

800-250-4519
4007 LOCKRIDGE STREET

www.westcoat.com
SAN DIEGO, CA. 92102

WESTCOAT POST FLASHING & REGLET DETAIL

NOT TO SCALE

NOTES:

- APPLY WP-51 ON ALL FLASHING SEAMS AND OVERLAPS. STANDARD OVERLAP IS BOTTOM TO TOP WITH A 4" OVERLAP.
- 2500 PSI MINIMUM FOR CONCRETE SUBSTRATES
- $\frac{5}{8}$ " EXTERIOR GRADE MINIMUM FOR PLYWOOD SUBSTRATE
- $\frac{1}{4}$ " MINIMUM SLOPE REQUIRED ON ALL DECKS
- REFER TO LOCAL BUILDING CODES & STANDARDS

**SITE BUILT
REGLET**

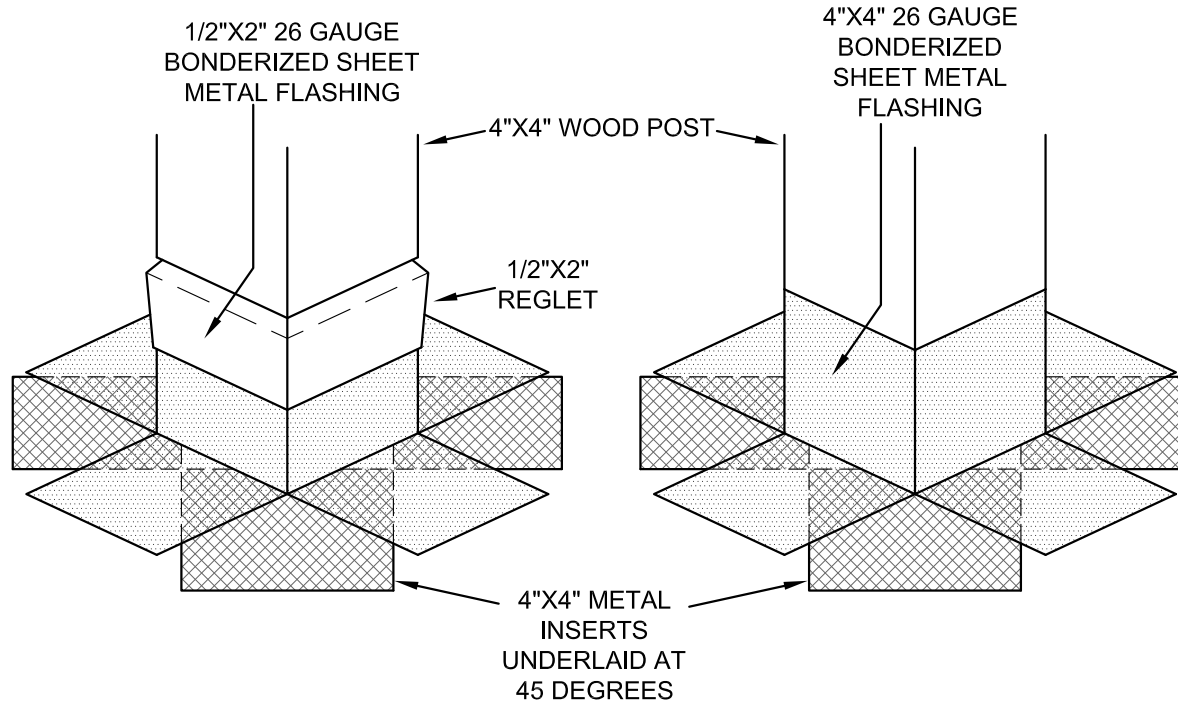
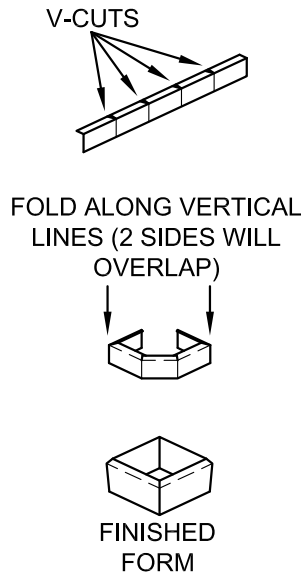

**SITE BUILT
FLASHING**

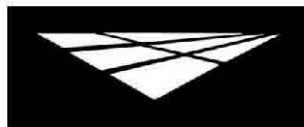
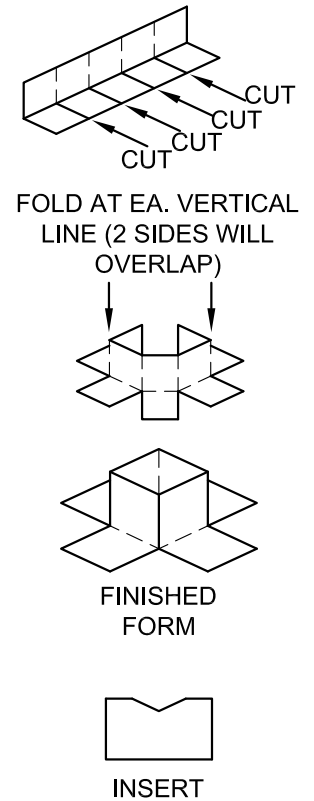

westcoat

800-250-4519
4007 LOCKRIDGE STREET

www.westcoat.com
SAN DIEGO, CA. 92102

WESTCOAT ALX INSIDE CORNER FLASHING DETAIL (OVER PLYWOOD)

NOT TO SCALE

NOTES:

- APPLY WP-51 ON ALL FLASHING SEAMS AND OVERLAPS. STANDARD OVERLAP IS BOTTOM TO TOP WITH A 4" OVERLAP.
- 2500 PSI MINIMUM FOR CONCRETE SUBSTRATES.
- $\frac{5}{8}$ " EXTERIOR GRADE MINIMUM FOR PLYWOOD SUBSTRATE.
- $\frac{1}{4}$ " MINIMUM SLOPE REQUIRED ON ALL DECKS.
- REFER TO LOCAL BUILDING CODES & STANDARDS.
- WP-40 SHEET MEMBRANE OPTIONAL EITHER UNDER OR OVER SHEET METAL.

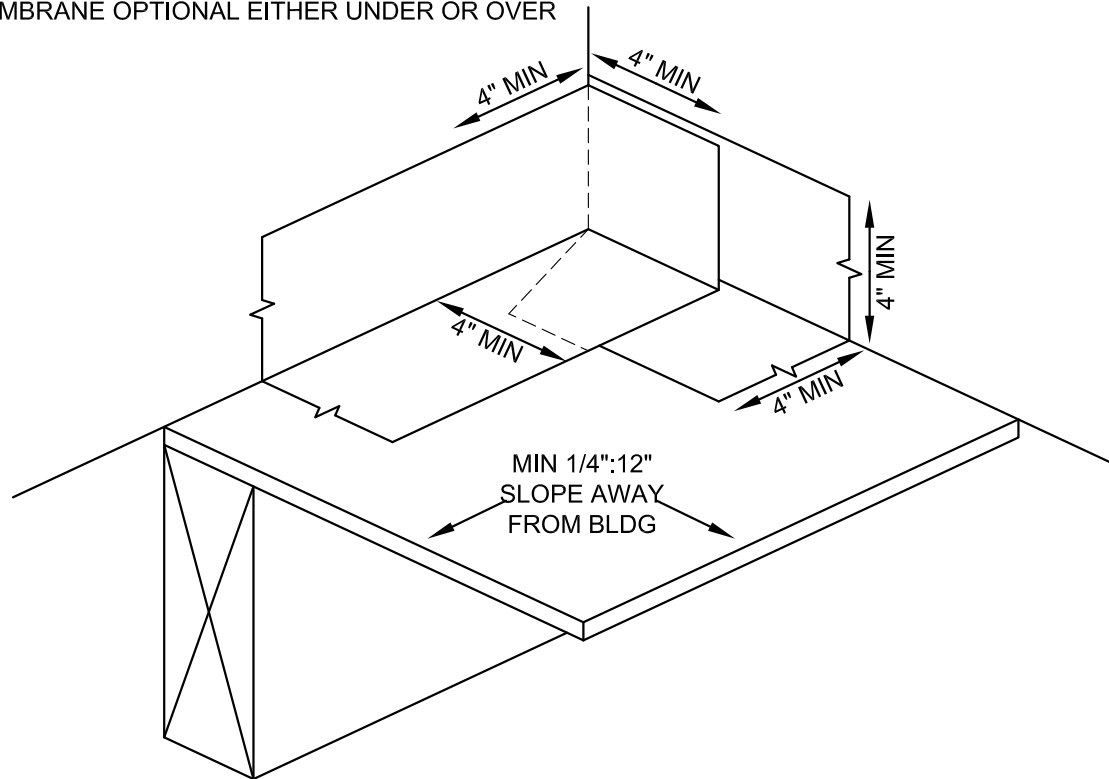

SITE BUILT PIECE

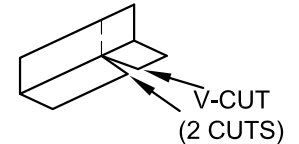
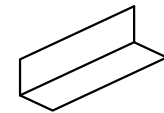

FOLD INWARD
ALONG HERE

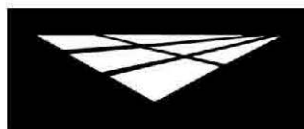
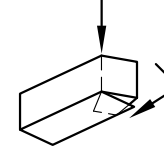

westcoat

800-250-4519
4007 LOCKRIDGE STREET

www.westcoat.com
SAN DIEGO, CA. 92102

WESTCOAT ALX OUTSIDE CORNER FLASHING DECK TERMINATION DETAIL (OVER WOOD)

NOT TO SCALE

NOTES:

- APPLY WP-51 ON ALL FLASHING SEAMS AND OVERLAPS. STANDARD OVERLAP IS BOTTOM TO TOP WITH A 4" OVERLAP.
- 2500 PSI MINIMUM FOR CONCRETE SUBSTRATES.
- $\frac{5}{8}$ " EXTERIOR GRADE MINIMUM FOR PLYWOOD SUBSTRATE.
- $\frac{1}{4}$ " MINIMUM SLOPE REQUIRED ON ALL DECKS.
- REFER TO LOCAL BUILDING CODES & STANDARDS.
- WP-40 SHEET MEMBRANE OPTIONAL EITHER UNDER OR OVER SHEET METAL.

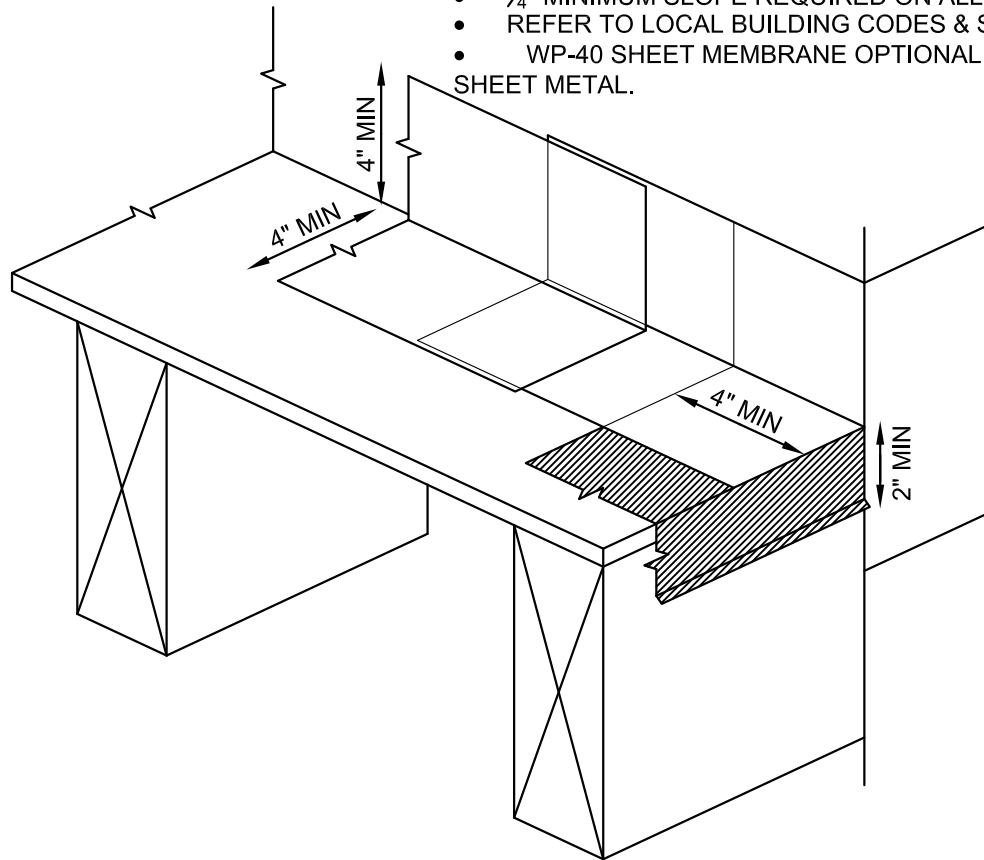

FIRST PIECE

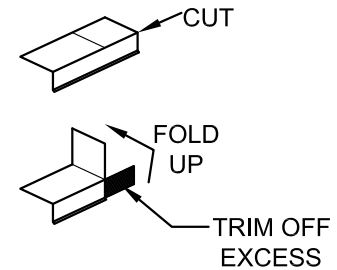

SECOND PIECE

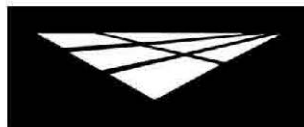
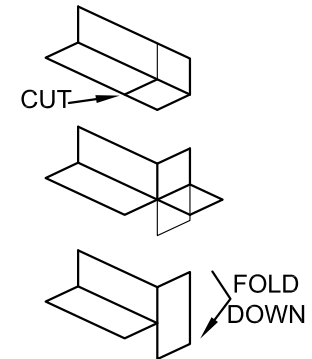

westcoat

800-250-4519
4007 LOCKRIDGE STREET

www.westcoat.com
SAN DIEGO, CA. 92102

WESTCOAT ALX OUTSIDE CORNER FLASHING DECK WRAPAROUND DETAIL (OVER WOOD)

NOT TO SCALE

NOTES:

- APPLY WP-51 ON ALL FLASHING SEAMS AND OVERLAPS. STANDARD OVERLAP IS BOTTOM TO TOP WITH A 4" OVERLAP.
- 2500 PSI MINIMUM FOR CONCRETE SUBSTRATES.
- $\frac{5}{8}$ " EXTERIOR GRADE MINIMUM FOR PLYWOOD SUBSTRATE.
- $\frac{1}{4}$ " MINIMUM SLOPE REQUIRED ON ALL DECKS.
- REFER TO LOCAL BUILDING CODES & STANDARDS.
- WP-40 SHEET MEMBRANE OPTIONAL EITHER UNDER OR OVER SHEET METAL.

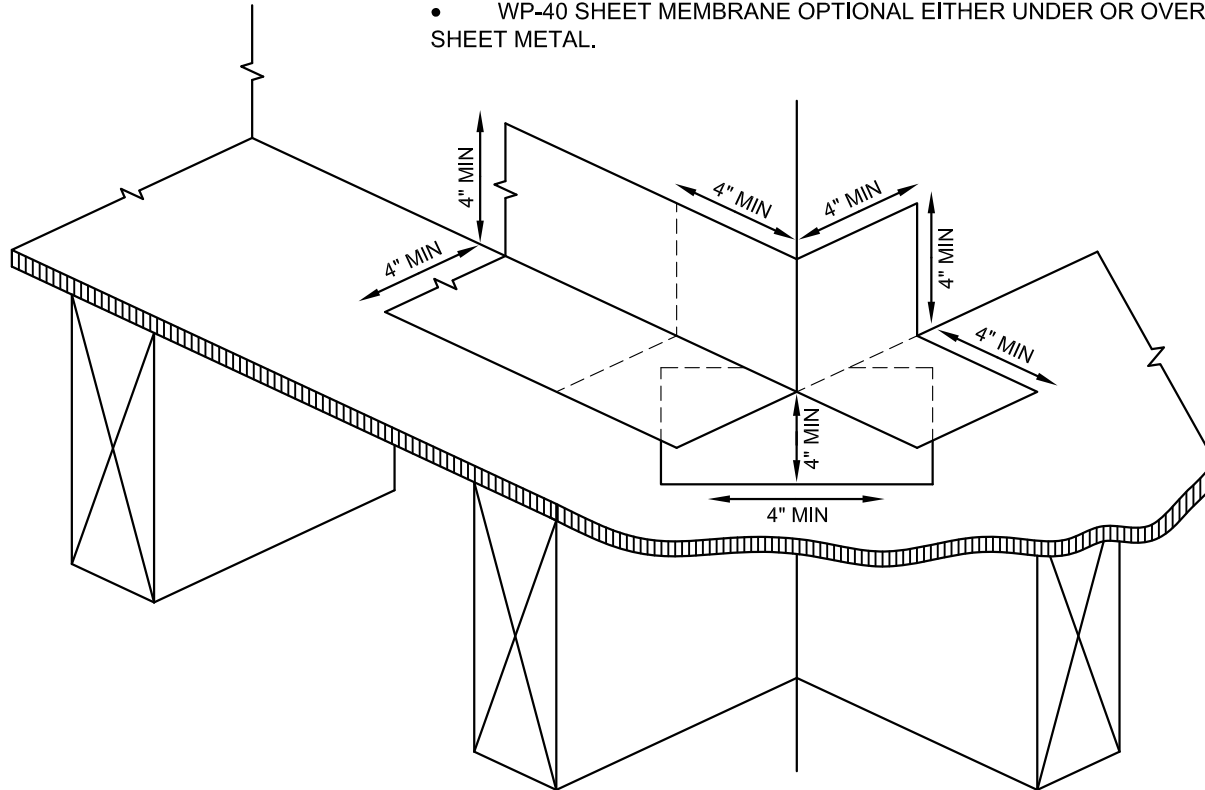

FIRST PIECE

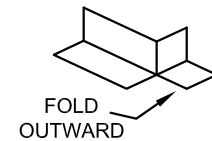
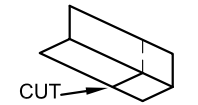

SECOND PIECE

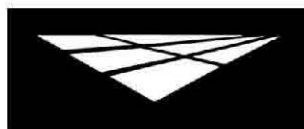

westcoat

800-250-4519
4007 LOCKRIDGE STREET

www.westcoat.com
SAN DIEGO, CA. 92102

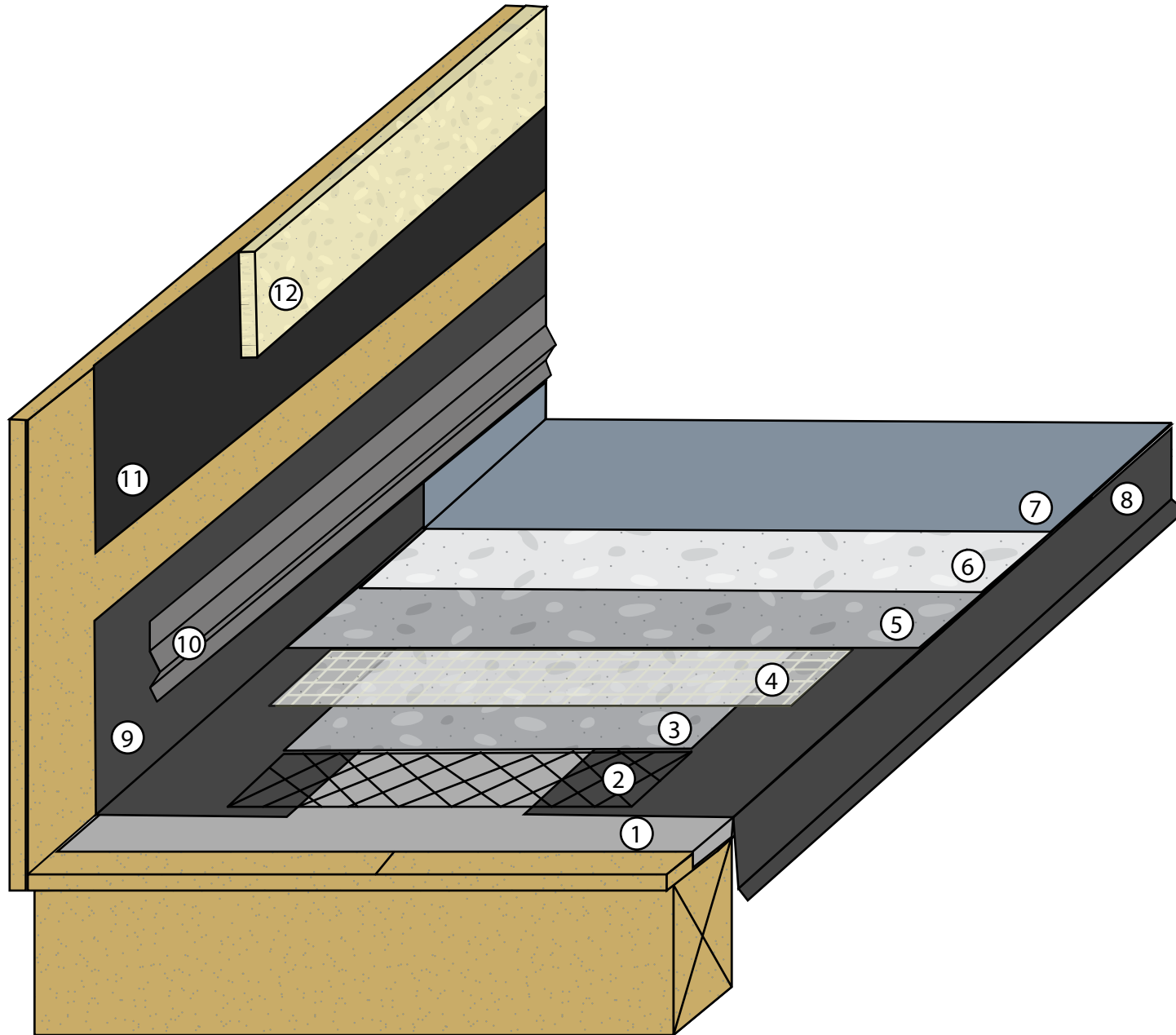

KEYNOTES

- ① WP-40 Sheet Membrane
- ② WP-25 Metal Lath
- ③ Base Coat
- ④ Fiberlath Resin Membrane
- ⑤ Slurry Coat
- ⑥ Texture Coat
- ⑦ SC-10 Topcoat
- ⑧ Drip Edge Metal (2"x4")
26 gauge, bonderized
- ⑨ Wall-to-deck "L" Metal (6"x4")
26 gauge, bonderized
- ⑩ Continuous drip screed
- ⑪ Building Paper
- ⑫ Wall Finish



Evaluation Report
ER - 587

- Refer to all related Product and System Specifications for additional information.
- Standard overlap is bottom to top with a 4" overlap.
- Apply WP-51 on all flashing seams and overlaps.
- Minimum 5/8" exterior grade plywood.
- Minimum 1/4" slope required on all decks
- Refer to local building codes and standards.

REV. 1/31/18 TC

ALX PRO STANDARD - OVERVIEW

DIVISION 07 18 13
Pedestrian Traffic Coatings

SCALE : NTS



westcoat
SPECIALTY COATING SYSTEMS

4007 Lockridge Street • San Diego, CA • 92102
800.250.4519 • westcoat.com

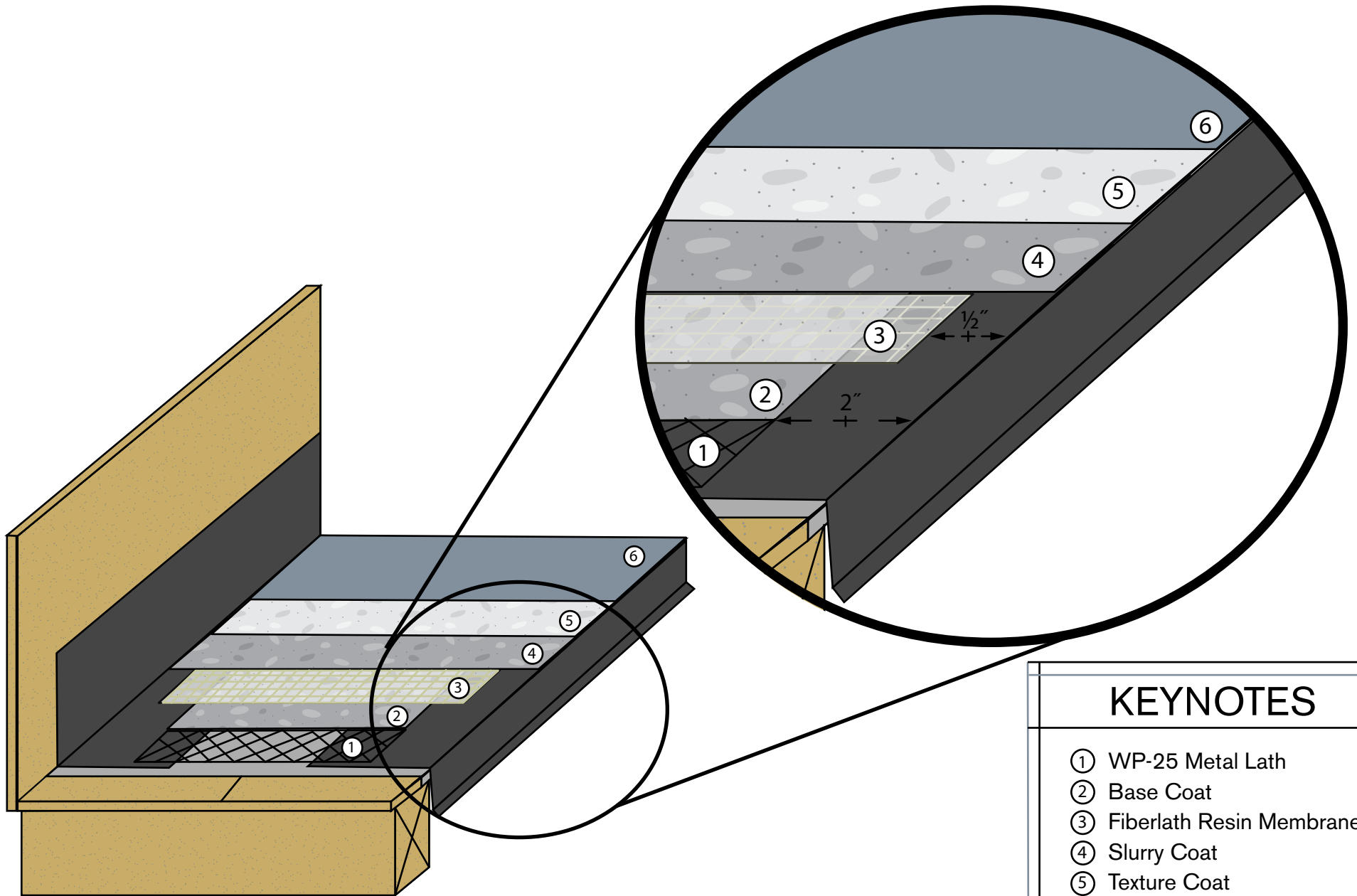

KEYNOTES

- ① WP-25 Metal Lath
- ② Base Coat
- ③ Fiberlath Resin Membrane
- ④ Slurry Coat
- ⑤ Texture Coat
- ⑥ SC-10 Topcoat

REV. 5/1/20 TC

ALX PRO STANDARD - EDGE DETAIL

DIVISION 07 18 13
Pedestrian Traffic Coatings

SCALE : NTS



westcoat

SPECIALTY COATING SYSTEMS

4007 Lockridge Street • San Diego, CA • 92102
800.250.4519 • westcoat.com

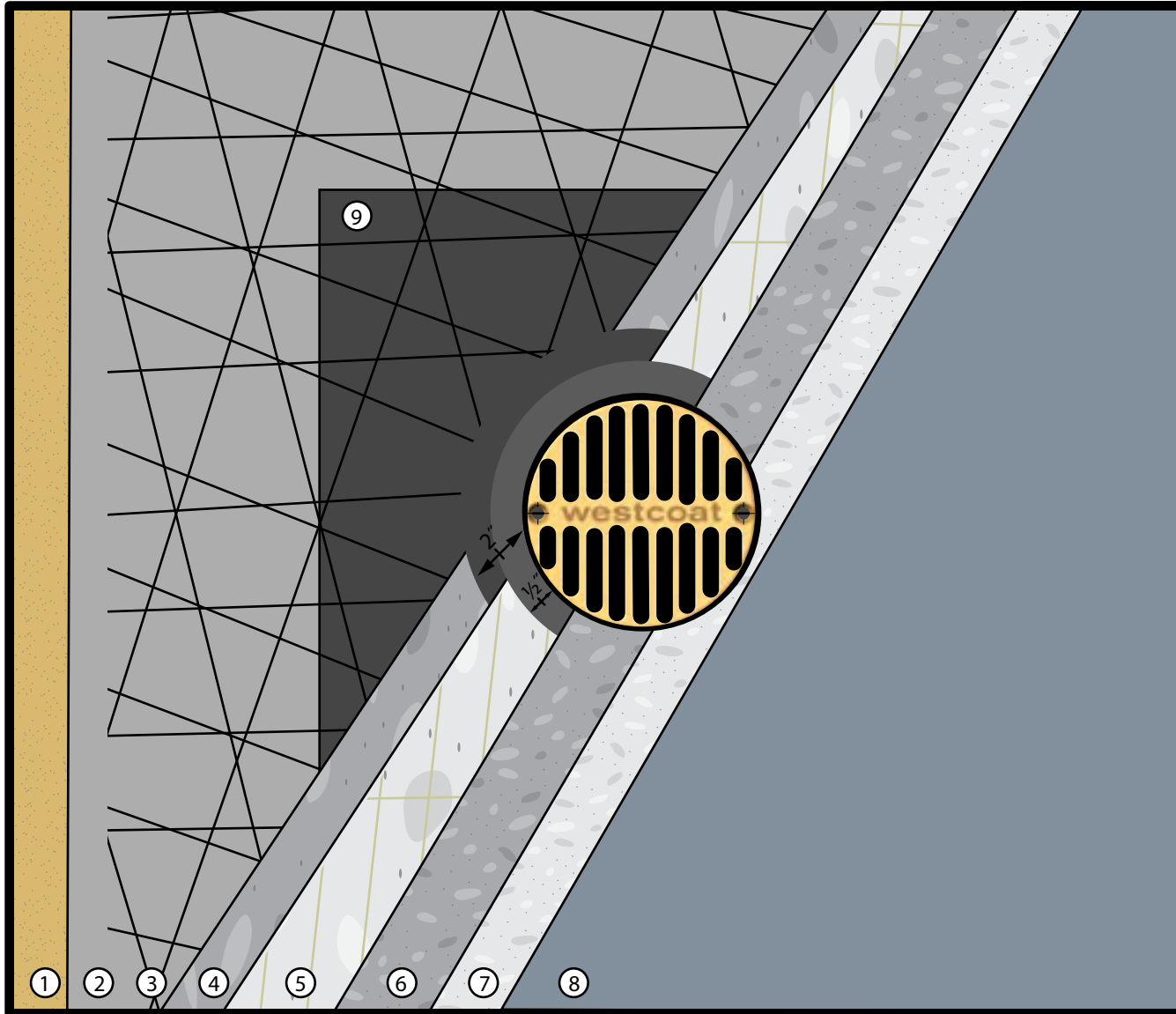

KEYNOTES

- ① 3/4" Exterior Grade Plywood
- ② WP-40 Sheet Membrane
- ③ WP-25 Metal Lath
- ④ Base Coat
- ⑤ Fiberlath Resin Membrane
- ⑥ Slurry Coat
- ⑦ Texture Coat
- ⑧ SC-10 Topcoat
- ⑨ WP-35 ALX Drain

REV. 5/1/20 TC

ALX PRO STANDARD - DRAIN DETAIL

DIVISION 07 18 13
Pedestrian Traffic Coatings

SCALE : NTS



westcoat
SPECIALTY COATING SYSTEMS

4007 Lockridge Street • San Diego, CA • 92102
800.250.4519 • westcoat.com

KEYNOTES

- ① 5/8" MIN. Exposure 1 Sheathing (3/4" Recommended)
- ② WP-40 Sheet Membrane
- ③ 26 Gauge, Bonderized Flashing MIN. 4" on deck and 6" height.
- ④ WP-25 Metal Lath
- ⑤ Base Coat
- ⑥ Fiberlath Resin Membrane
- ⑦ Slurry Coat
- ⑧ Texture Coat and Topcoat
- ⑨ Building Paper (By Others)
- ⑩ Siding (By Others)

IAPMO ER - 587

- Standard overlap is bottom to top with a 4" overlap.
- Apply WP-51 on all flashing seams and overlaps.
- Minimum 5/8" exterior grade plywood.
- Minimum 1/4" slope required on all decks
- Refer to local building codes and standards.

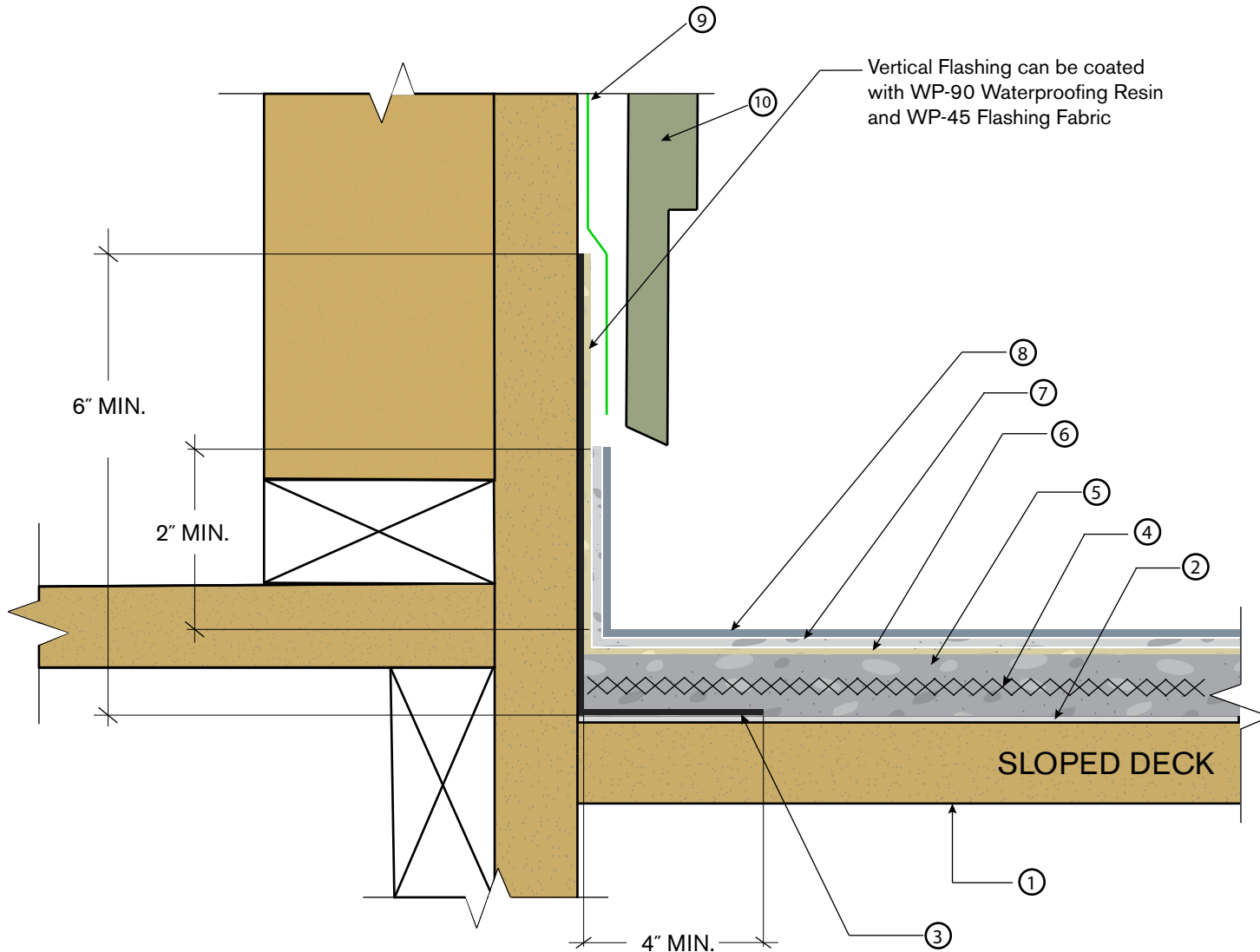

ALX PRO - DECK TO WALL FLASHING - SIDING

DIVISION 07 18 13
Pedestrian Traffic Coatings

SCALE : NTS



westcoat
SPECIALTY COATING SYSTEMS

4007 Lockridge Street • San Diego, CA • 92102
800.250.4519 • westcoat.com

KEYNOTES

- ① 5/8" MIN. Exposure 1 Sheathing (3/4" Recommended)
- ② WP-40 Sheet Membrane
- ③ 26 Gauge, Bonderized Flashing MIN. 4" on deck and 6" height.
- ④ WP-25 Metal Lath
- ⑤ Base Coat
- ⑥ Fiberlath Resin Membrane
- ⑦ Slurry Coat
- ⑧ Texture Coat and Topcoat
- ⑨ Stucco Stop (By Others)
- ⑩ Building Paper (By Others)
- ⑪ Stucco Finish (By Others)

IAPMO ER - 587

- Standard overlap is bottom to top with a 4" overlap.
- Apply WP-51 on all flashing seams and overlaps.
- Minimum 5/8" exterior grade plywood.
- Minimum 1/4" slope required on all decks
- Refer to local building codes and standards.

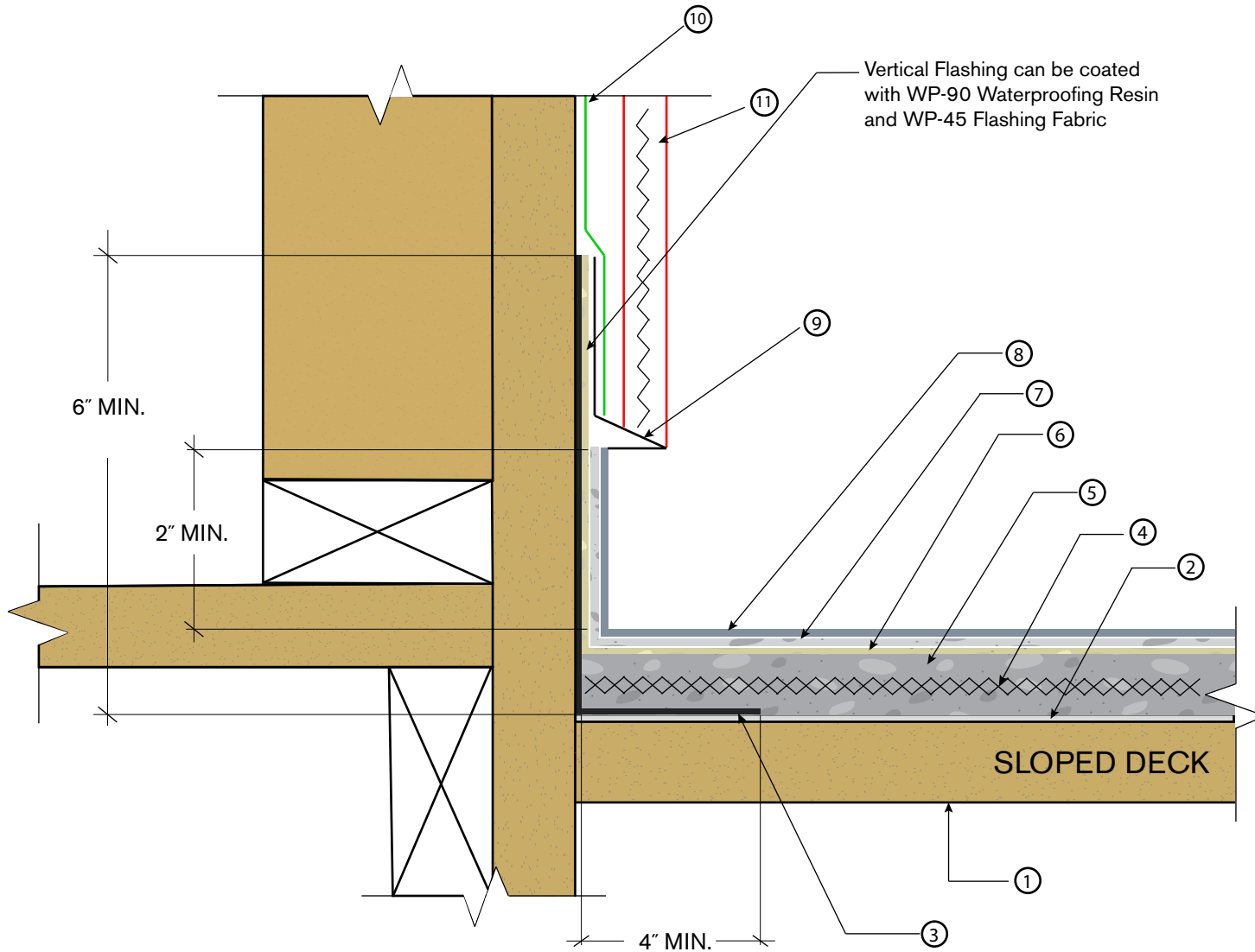

ALX PRO - DECK TO WALL FLASHING - STUCCO OR EIFS

DIVISION 07 18 13
Pedestrian Traffic Coatings

SCALE : NTS



westcoat
SPECIALTY COATING SYSTEMS

4007 Lockridge Street • San Diego, CA • 92102
800.250.4519 • westcoat.com

KEYNOTES

- ① 5/8" MIN. Exposure 1 Sheathing (3/4" Recommended)
- ② WP-40 Sheet Membrane
- ③ 26 Gauge, Bonderized Flashing MIN. 4" on deck and 6" height.
- ④ WP-25 Metal Lath
- ⑤ Base Coat
- ⑥ Fiberlath Resin Membrane
- ⑦ Slurry Coat
- ⑧ Texture Coat and Topcoat
- ⑨ Building Paper (By Others)
- ⑩ Stucco Finish (By Others)

IAPMO ER - 587

- Metal Lath and Base Coat held back from edge by 2"
- Fiberlath Resin Membrane held back from edge by 1/2"
- Slurry Coat, Texture Coat and Topcoat applied to edge of deck.
- Standard overlap is bottom to top with a 4" overlap.
- Apply WP-51 on all flashing seams and overlaps.
- Minimum 5/8" exterior grade plywood.
- Minimum 1/4" slope required on all decks
- Refer to local building codes and standards.

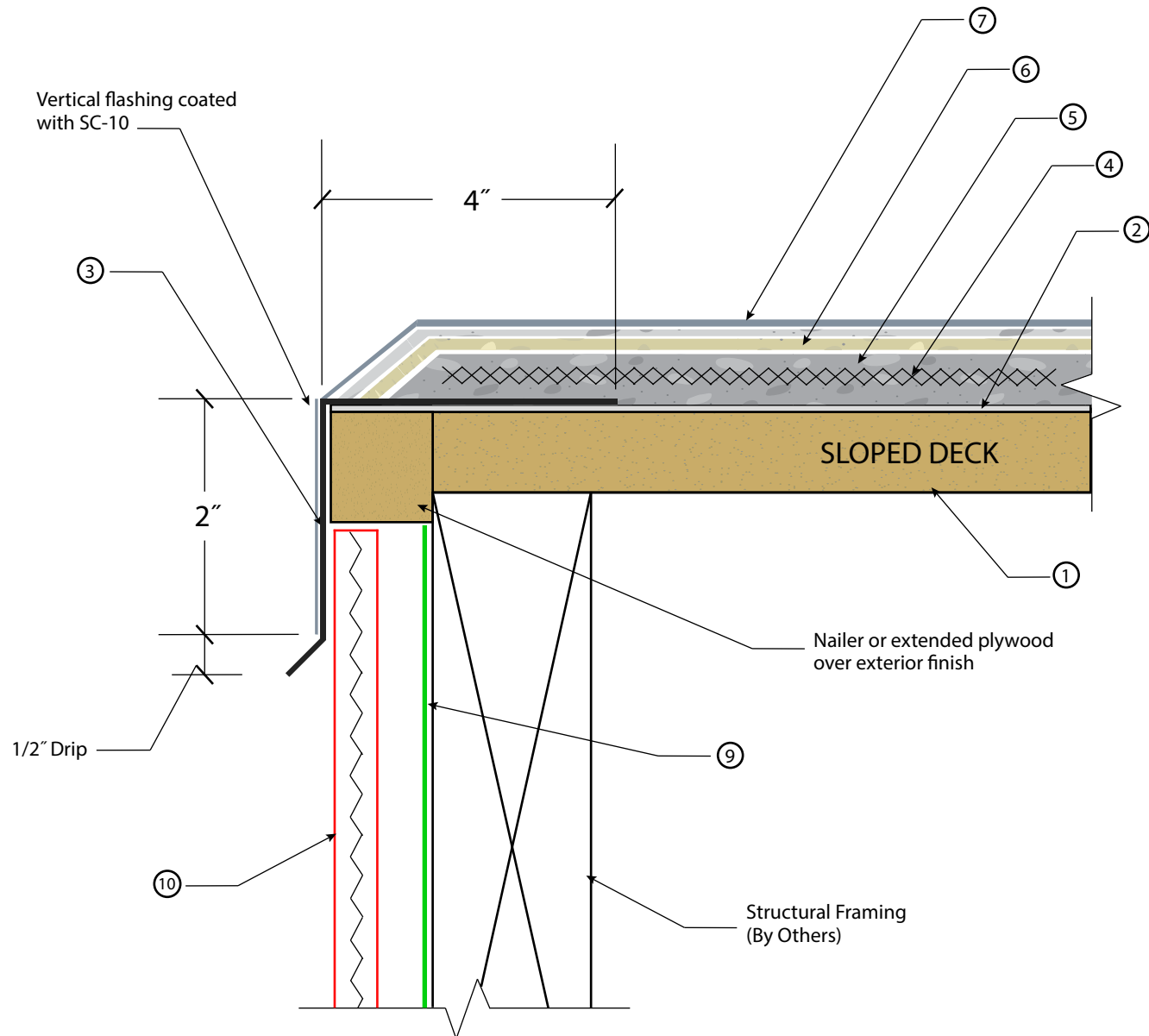

ALX PRO - EDGE METAL FLASHING OVER STUCCO FASCIA

DIVISION 07 18 13
Pedestrian Traffic Coatings

SCALE : NTS



westcoat
SPECIALTY COATING SYSTEMS

4007 Lockridge Street • San Diego, CA • 92102
800.250.4519 • westcoat.com

KEYNOTES

- ① WP-40 Sheet Membrane
- ② WP-25 Metal Lath
- ③ Base Coat
- ④ Fiberlath Resin Membrane
- ⑤ Slurry Coat
- ⑥ Texture Coat and Topcoat
- ⑦ Scupper (by others)
- ⑧ Exterior Facade (by others)
- ⑨ Structural Design (by others)
- ⑩ 5/8" MIN. Exposure 1 Sheathing (3/4" Recommended)

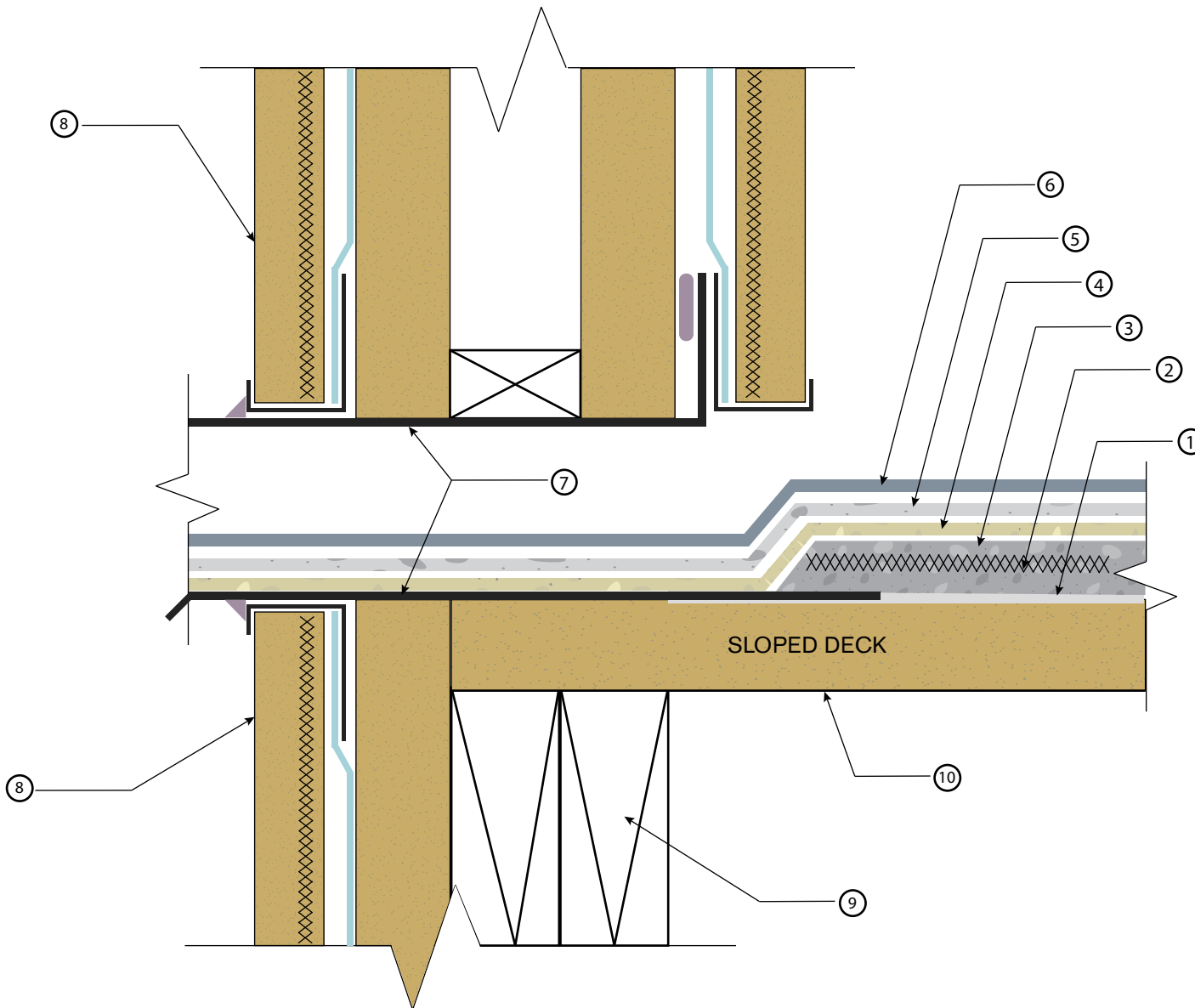

IAPMO ER - 587

- Standard overlap is bottom to top with a 4" overlap.
- Apply WP-51 on all flashing seams and overlaps.
- Minimum 5/8" exterior grade plywood.
- Minimum 1/4" slope required on all decks
- Refer to local building codes and standards.

ALX PRO SYSTEM - SCUPPER DETAIL

DIVISION 07 18 13
Pedestrian Traffic Coatings

SCALE : NTS



westcoat
SPECIALTY COATING SYSTEMS

4007 Lockridge Street • San Diego, CA • 92102
800.250.4519 • westcoat.com

KEYNOTES

- ① 5/8" MIN. Exposure 1 Sheathing (3/4" Recommended)
- ② WP-40 Sheet Membrane
- ③ 26 Gauge, Bonderized Flashing MIN. 4" on deck and 6" height.
- ④ WP-25 Metal Lath
- ⑤ Base Coat
- ⑥ Fiberlath Resin Membrane
- ⑦ Slurry Coat
- ⑧ Texture Coat and Topcoat
- ⑨ Building Paper (By Others)
- ⑩ Finish (By Others)

IAPMO ER - 587

- Metal Lath and Base Coat held back from edge by 2"
- Fiberlath Resin Membrane held back from edge by 1/2"
- Slurry Coat, Texture Coat and Topcoat applied to edge of deck.
- Standard overlap is bottom to top with a 4" overlap.
- Apply WP-51 on all flashing seams and overlaps.
- Minimum 5/8" exterior grade plywood.
- Minimum 1/4" slope required on all decks
- Refer to local building codes and standards.

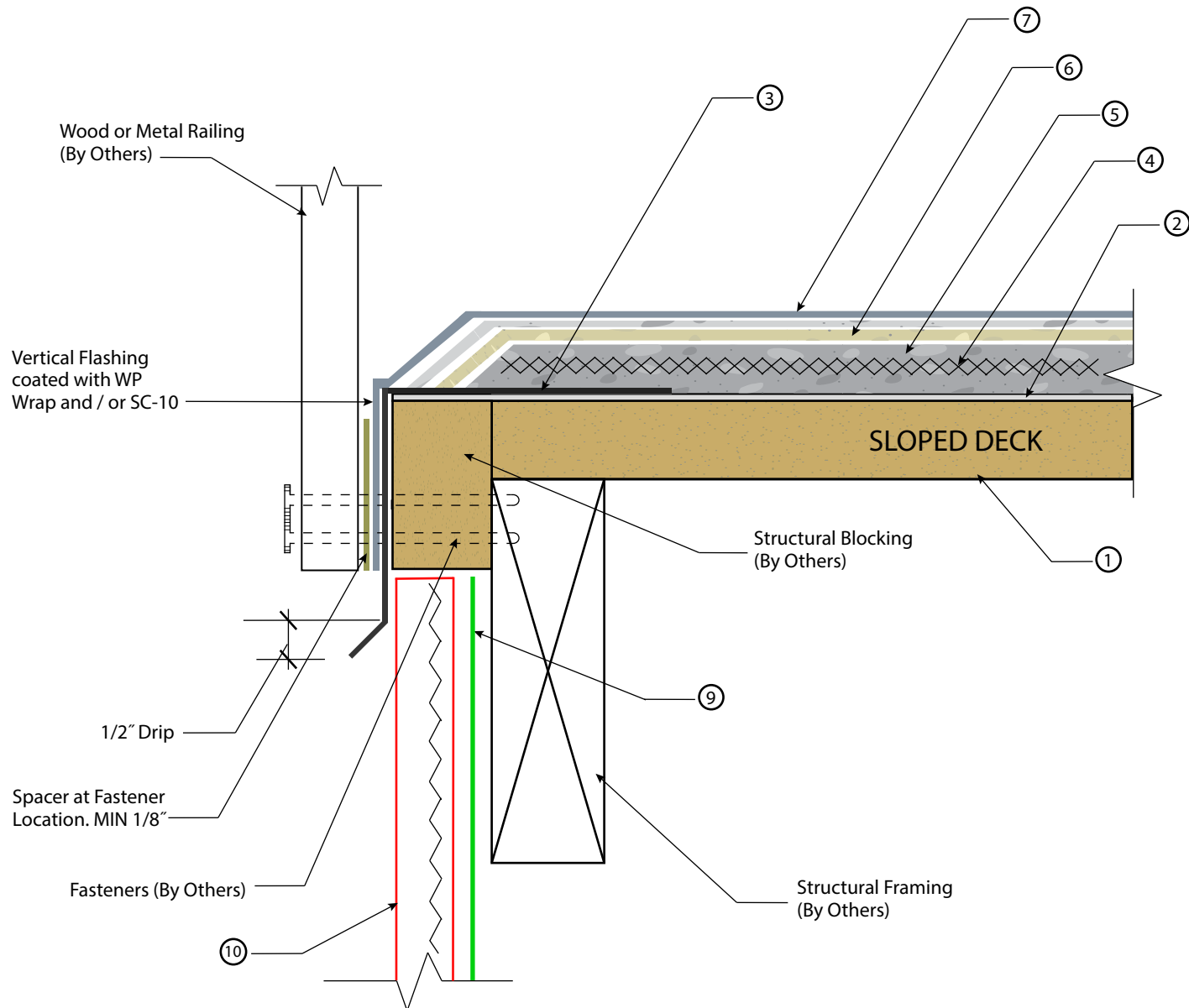

ALX PRO - DECK RAILING - SIDE MOUNTED

DIVISION 07 18 13
Pedestrian Traffic Coatings

SCALE : NTS



westcoat
SPECIALTY COATING SYSTEMS
4007 Lockridge Street • San Diego, CA • 92102
800.250.4519 • westcoat.com

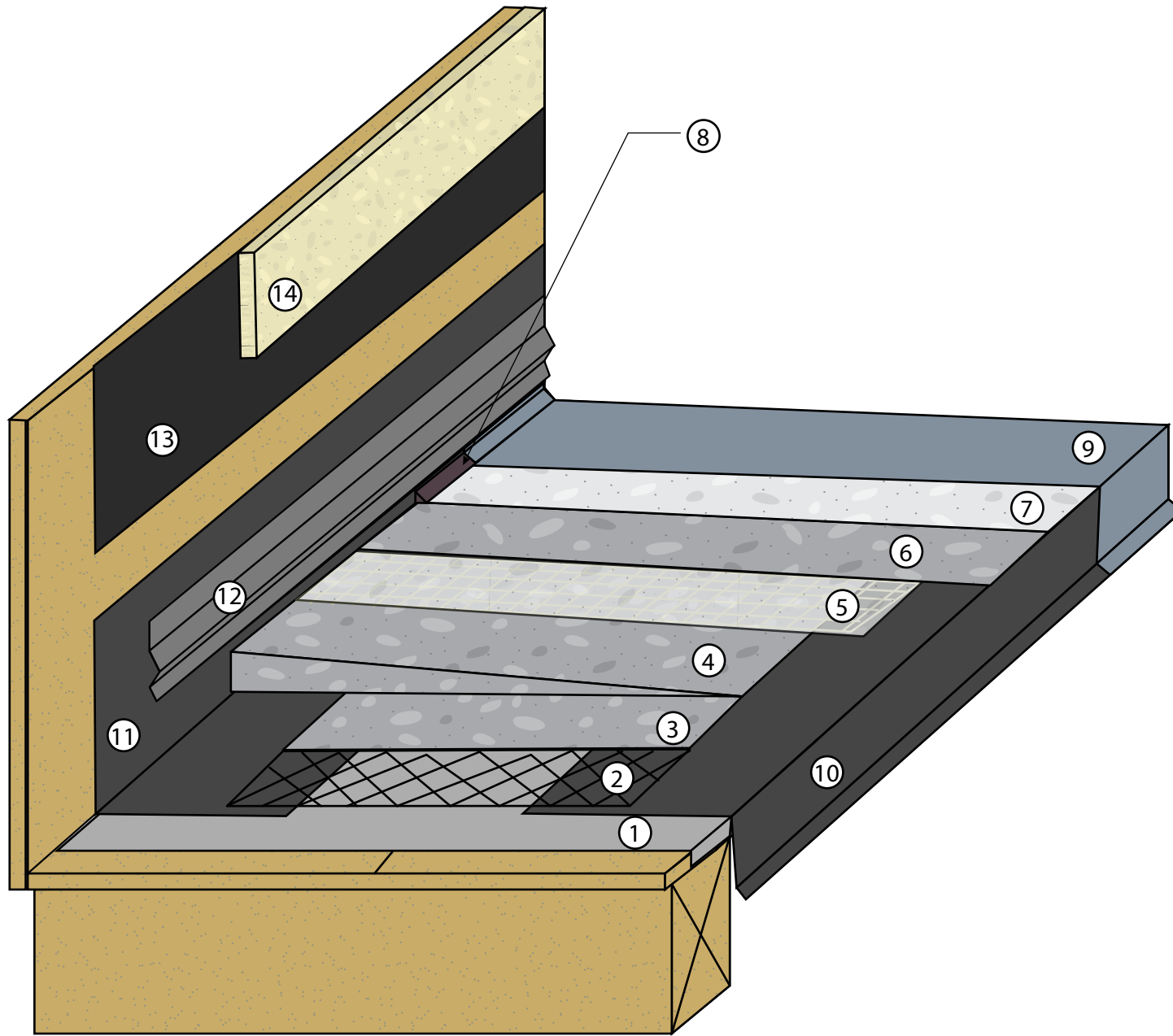

KEYNOTES

- ① WP-40 Sheet Membrane
- ② WP-25 Metal Lath
- ③ Base Coat
- ④ Westcoat Slope Technique
- ⑤ Fiberlath Resin Membrane
- ⑥ Slurry Coat
- ⑦ Texture Coat
- ⑧ WP-51 Polyurethane Sealant
- ⑨ SC-10 Topcoat
- ⑩ Drip Edge Metal (2"x4")
26 gauge, bonderized
- ⑪ Wall-to-deck "L" Metal (6"x4")
26 gauge, bonderized
- ⑫ Continuous drip screed
- ⑬ Building Paper
- ⑭ Wall Finish

IAPMO ER-587

- Standard overlap is bottom to top with a 4" overlap.
- Apply WP-51 on all flashing seams and overlaps.
- Minimum 5/8" exterior grade plywood.
- Minimum 1/4" slope required on all decks
- Refer to local building codes and standards.

REV. 9/25/23 TC

SLOPE TECHNIQUE - ALX PRO

DIVISION 07 18 13
Pedestrian Traffic Coatings

SCALE : NTS



westcoat
SPECIALTY COATING SYSTEMS
4007 Lockridge Street · San Diego, CA · 92102
800.250.4519 · westcoat.com

Step 1. Sheet Membrane & Sheet Metal

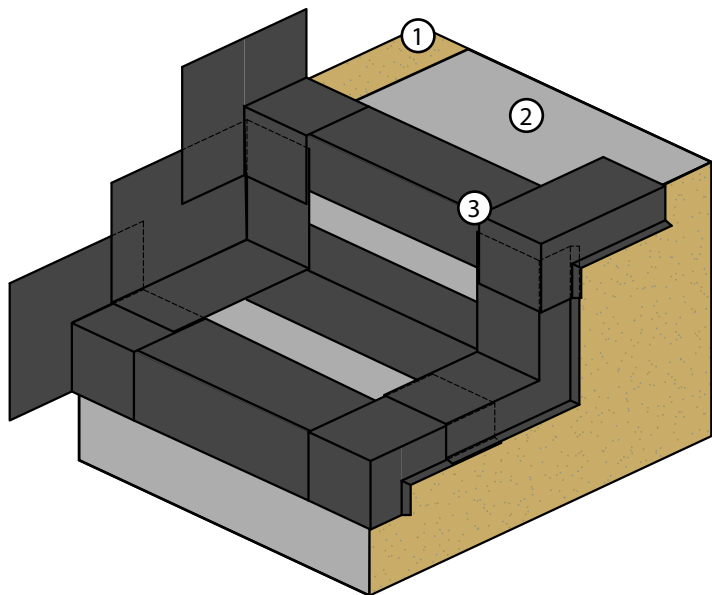

Step 2. Metal Lath and Base Coat

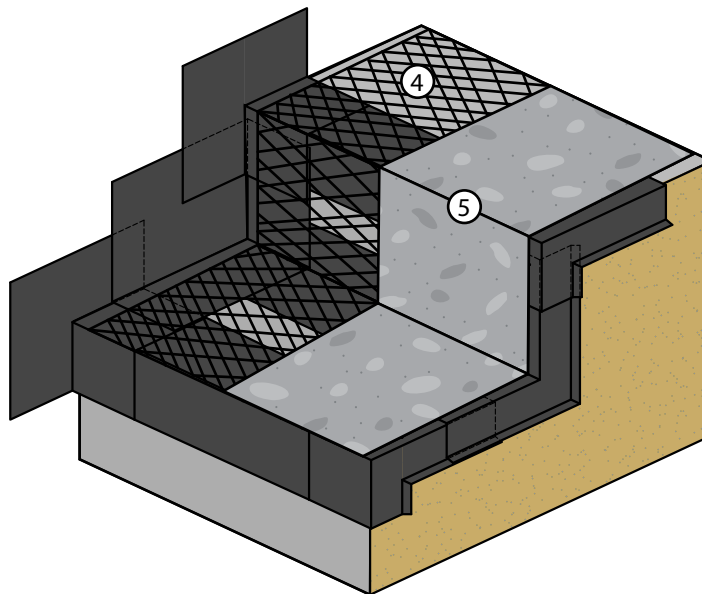

Step 3. WP Wrap

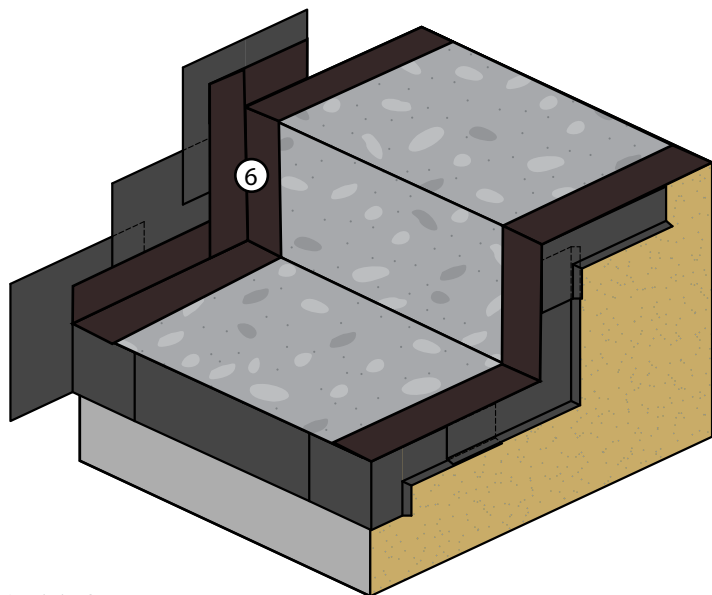

Step 4. Fiberlath Resin Membrane, Slurry Coat, Texture Coat and Topcoat.

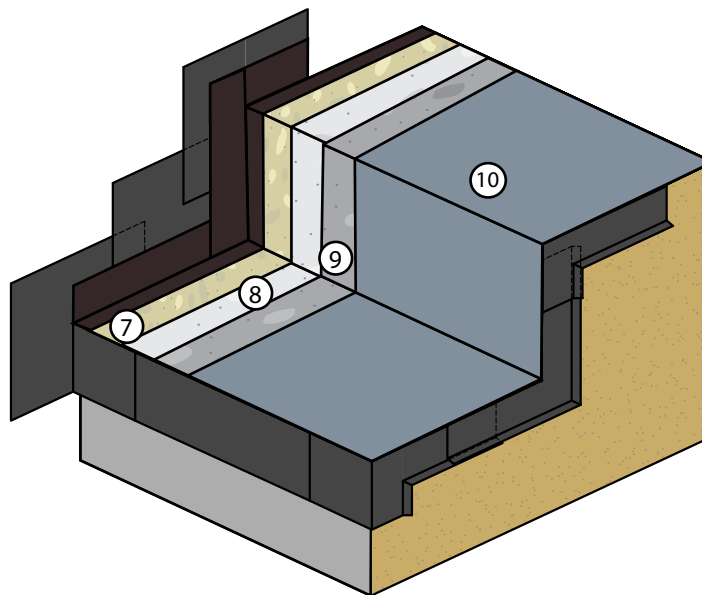

KEYNOTES

- ① Plywood Substrate
- ② WP-40 Sheet Membrane
- ③ 26 gauge Bonderized Sheet Metal
- ④ WP-25 Metal Lath
- ⑤ Base Coat
- ⑥ WP Wrap
- ⑦ Fiberlath Resin Membrane
- ⑧ Slurry Coat
- ⑨ Texture Coat
- ⑩ SC-10 Topcoat

IAPMO - ER-587

- Standard overlap is bottom to top with a 4" overlap.
- Apply WP-51 on all flashing seams and overlaps.
- Minimum 5/8" exterior grade plywood.
- Minimum 1/4" slope required on all decks
- Refer to local building codes and standards.
- Refer to all related Product and System Specifications for additional information.

REV. 9/25/23 TC

ALX PRO WITH WP WRAP - STAIR DETAIL

DIVISION 07 18 13
Pedestrian Traffic Coatings

SCALE : NTS



westcoat
SPECIALTY COATING SYSTEMS

4007 Lockridge Street • San Diego, CA • 92102
800.250.4519 • westcoat.com

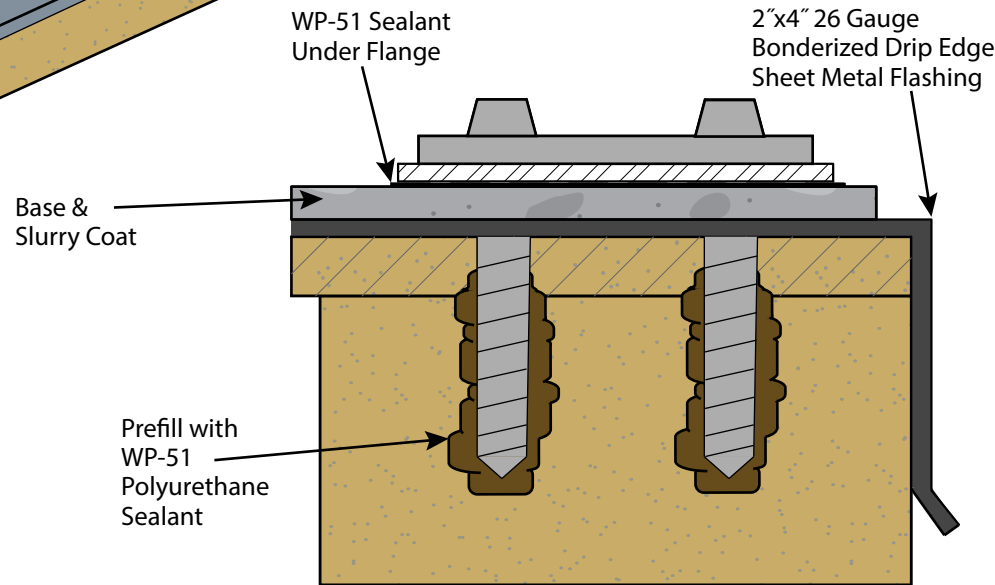
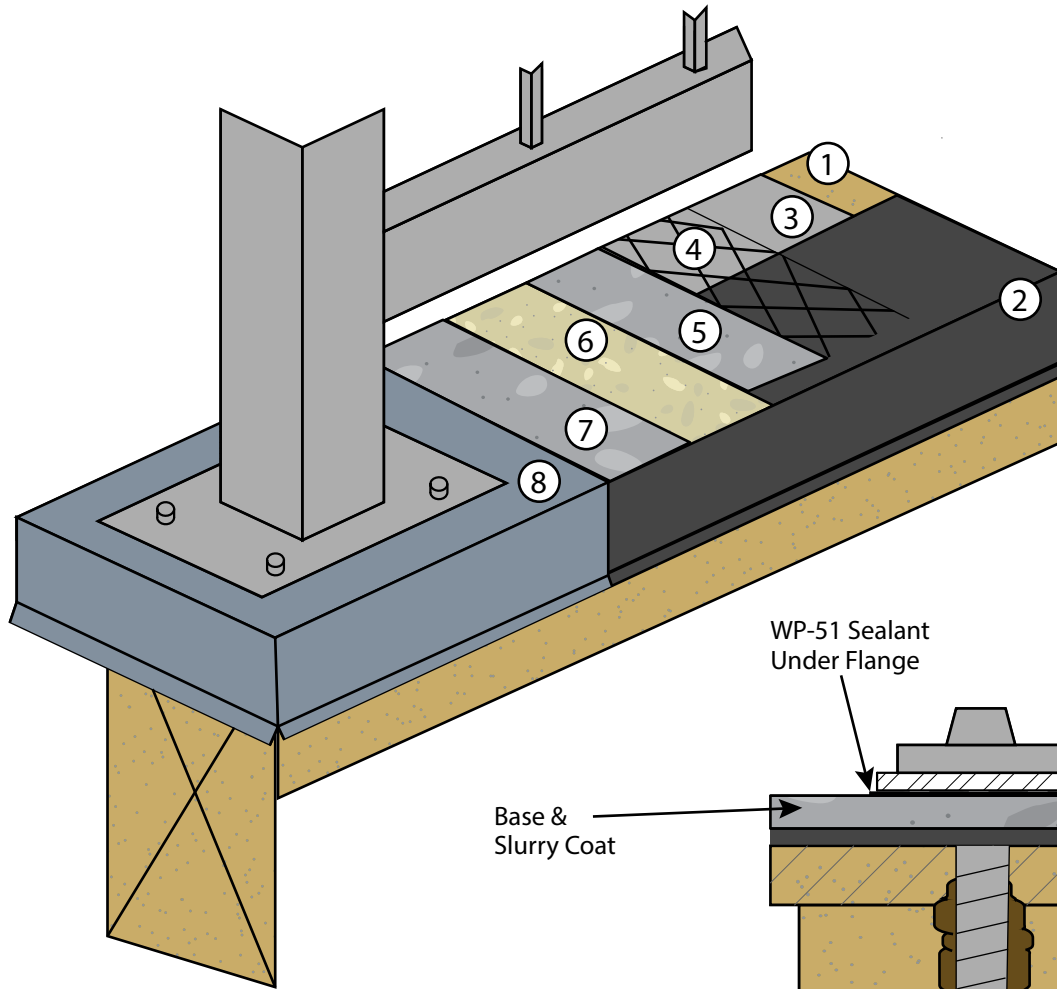

SIDE PROFILE

KEYNOTES

- ① Plywood (by others)
- ② Bonderized Metal Flashing
- ③ WP-40 Sheet Membrane
- ④ WP-25 Metal Lath
- ⑤ Base Coat
- ⑥ Fiberlath Resin Membrane
- ⑦ Slurry Coat
- ⑧ Texture Coat & Topcoat

IAPMO ER-587

POST TO BE INSTALLED ON TOP OF SLURRY COAT.
 TEXTURE COAT SHOULD BE APPLIED AFTER POST FLANGE INSTALL

- Standard overlap is bottom to top with a 4" overlap.
- Apply WP-51 on all flashing seams and overlaps.
- Minimum 5/8" exterior grade plywood.
- Minimum 1/4" slope required on all decks
- Refer to local building codes and standards.
- Refer to all related Product and System Specifications for additional information.
- Shows best option for top mount. Side mount is recommended for all railings.

REV.6/11/21 TC

ALX PRO SYSTEM - TOP MOUNT RAILING DETAIL

DIVISION 07 18 13
 Pedestrian Traffic Coatings

SCALE : NTS



westcoat
 SPECIALTY COATING SYSTEMS
 4007 Lockridge Street • San Diego, CA • 92102
 800.250.4519 • westcoat.com

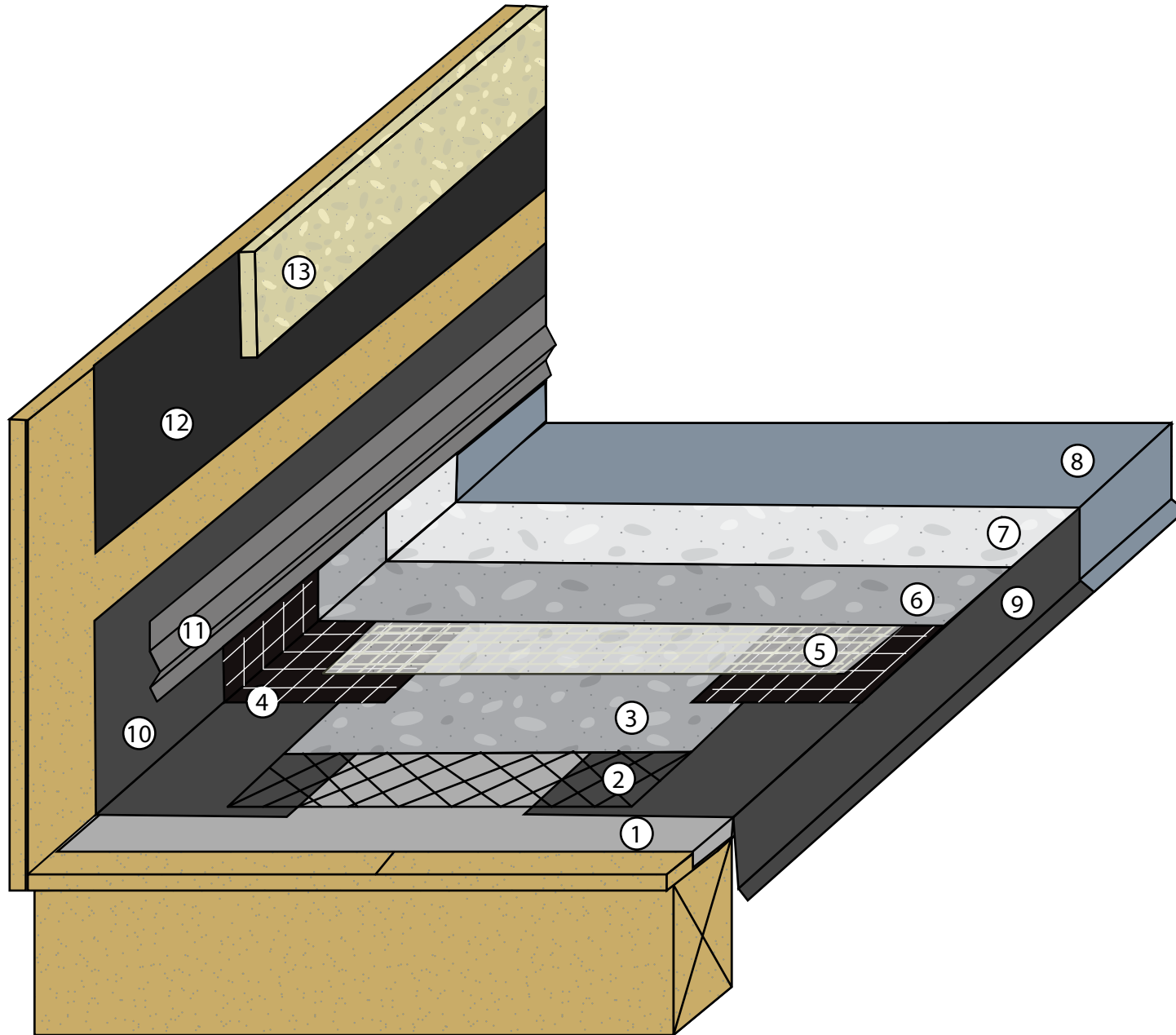

KEYNOTES

- ① WP-40 Sheet Membrane
- ② WP-25 Metal Lath
- ③ Base Coat
- ④ WP Wrap: WP-95 + WP-45
- ⑤ Fiberlath Resin Membrane
- ⑥ Slurry Coat
- ⑦ Texture Coat
- ⑧ SC-10 Topcoat
- ⑨ Drip Edge Metal (2"x4")
26 gauge, bonderized
- ⑩ Wall-to-deck "L" Metal (6"x4")
26 gauge, bonderized
- ⑪ Continuous drip screed (by others)
- ⑫ Building Paper (by others)
- ⑬ Wall Finish (by others)

IAPMO ER-587

- Standard overlap is bottom to top with a 4" overlap.
- Apply WP-51 on all flashing seams and overlaps.
- Minimum 5/8" exterior grade plywood.
- Minimum 1/4" slope required on all decks
- Refer to local building codes and standards.
- Refer to all related Product and System Specifications for additional information.

REV. 10/21/22 TC

WP WRAP - ALX PRO STANDARD

DIVISION 07 18 13
Pedestrian Traffic Coatings

SCALE : NTS



westcoat
SPECIALTY COATING SYSTEMS

4007 Lockridge Street • San Diego, CA • 92102
800.250.4519 • westcoat.com

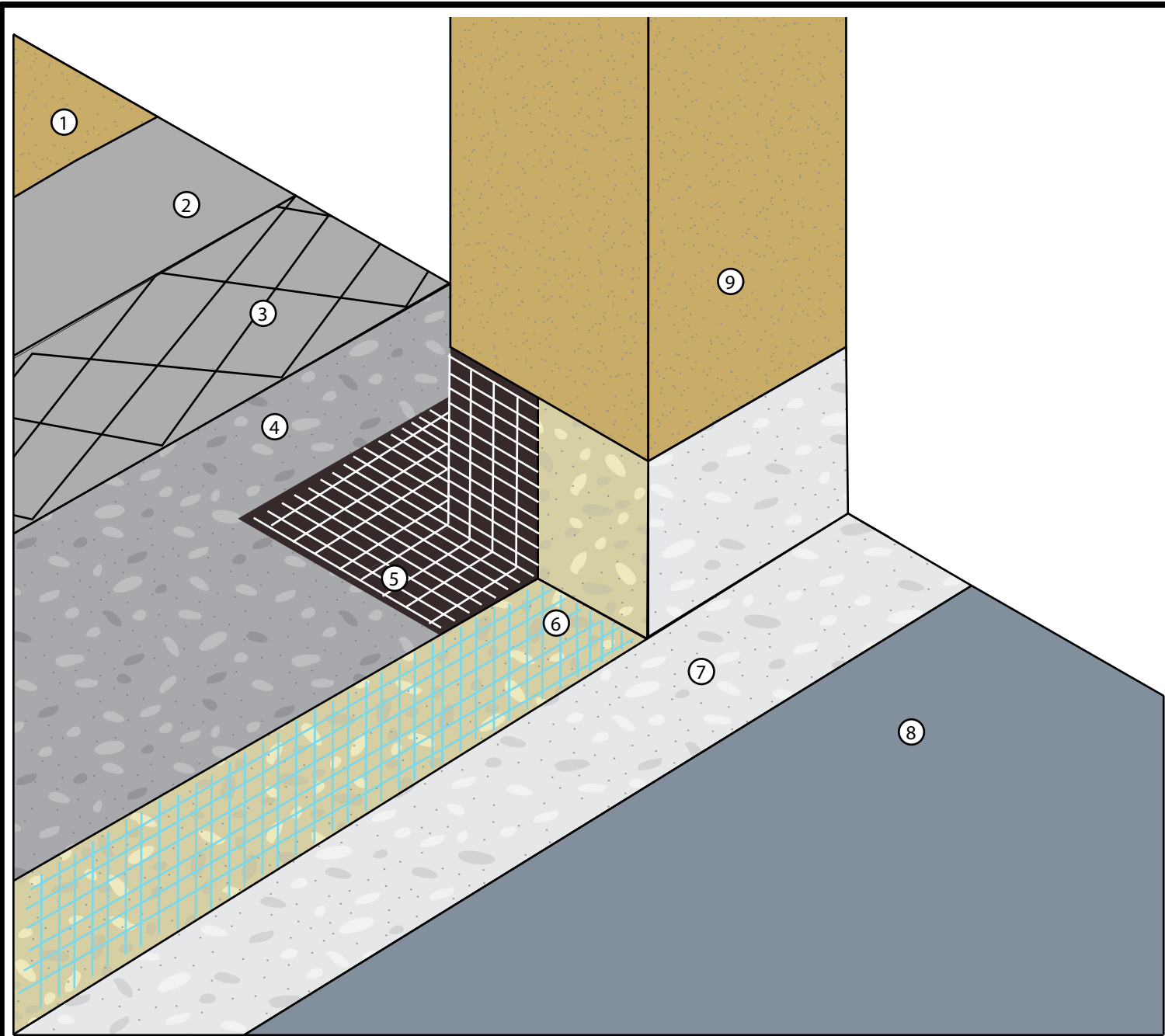

KEYNOTES	
①	Plywood Substrate
②	WP-40 Sheet Membrane
③	WP-25 Metal Lath
④	Base Coat
⑤	WP Wrap: WP-95 & WP-45
⑥	Fiberlath Resin Membrane
⑦	Slurry Coat
⑧	Texture & Topcoat
⑨	Post

IAPMO ER-587	
<ul style="list-style-type: none"> •Minimum 5/8" exterior grade plywood. •Minimum 1/4" slope required on all decks •Refer to local building codes and standards. •Refer to all related Product and System Specifications for additional information. 	

WP WRAP - POST DETAIL - ALX PRO STANDARD

DIVISION 07 18 13
Pedestrian Traffic Coatings

SCALE : NTS

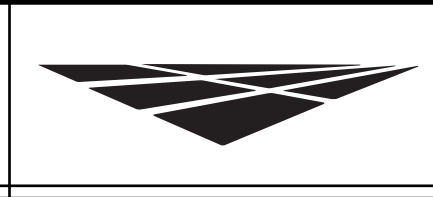

westcoat
SPECIALTY COATING SYSTEMS
4007 Lockridge Street • San Diego, CA • 92102
800.250.4519 • westcoat.com