

WESTCOAT ALX TOPMOUNT RAILING DETAIL (OVER WOOD)

NOT TO SCALE

IMPORTANT NOTES:

1. POST TO BE INSTALLED ON TOP OF SLURRY COAT.
2. TEXTURE COAT SHOULD BE APPLIED AFTER POST FLANGE INSTALL

NOTES:

- APPLY WP-51 ON ALL FLASHING SEAMS AND OVERLAPS. STANDARD OVERLAP IS BOTTOM TO TOP WITH A 4" OVERLAP.
- 2500 PSI MINIMUM FOR CONCRETE SUBSTRATES.
- 5/8" EXTERIOR GRADE MINIMUM FOR PLYWOOD SUBSTRATE.
- 1/4" MINIMUM SLOPE REQUIRED ON ALL DECKS.
- REFER TO LOCAL BUILDING CODES & STANDARDS.
- WP-40 SHEET MEMBRANE OPTIONAL EITHER UNDER OR OVER SHEET METAL.
- SHOWS BEST OPTION FOR TOPMOUNT, SIDEMOUNT IS RECOMMENDED FOR ALL RAILINGS

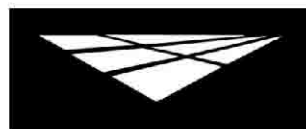
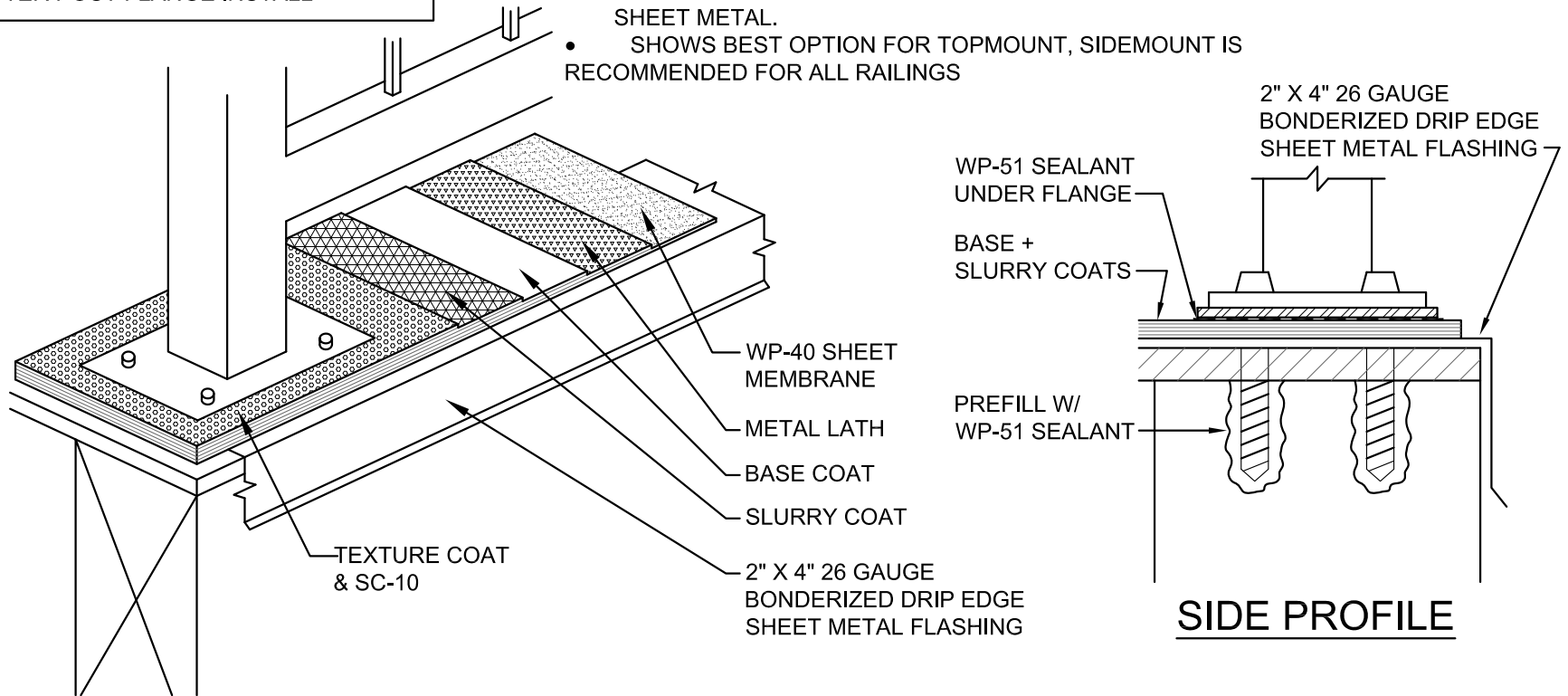

westcoat

800-250-4519
770 GATEWAY CENTER DRIVE

www.westcoat.com
SAN DIEGO, CA. 92102