

WESTCOAT ALX DECK EDGE & WALL-TO-DECK DETAIL (OVER PLYWOOD)

NOT TO SCALE

NOTES:

- APPLY WP-51 ON ALL FLASHING SEAMS AND OVERLAPS. STANDARD OVERLAP IS BOTTOM TO TOP WITH A 4" OVERLAP.
- 2500 PSI MINIMUM FOR CONCRETE SUBSTRATES.
- $\frac{5}{8}$ " EXTERIOR GRADE MINIMUM FOR PLYWOOD SUBSTRATE.
- $\frac{1}{4}$ " MINIMUM SLOPE REQUIRED ON ALL DECKS.
- REFER TO LOCAL BUILDING CODES & STANDARDS.
- WP-40 SHEET MEMBRANE OPTIONAL EITHER UNDER OR OVER SHEET METAL.

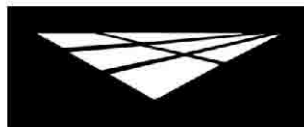
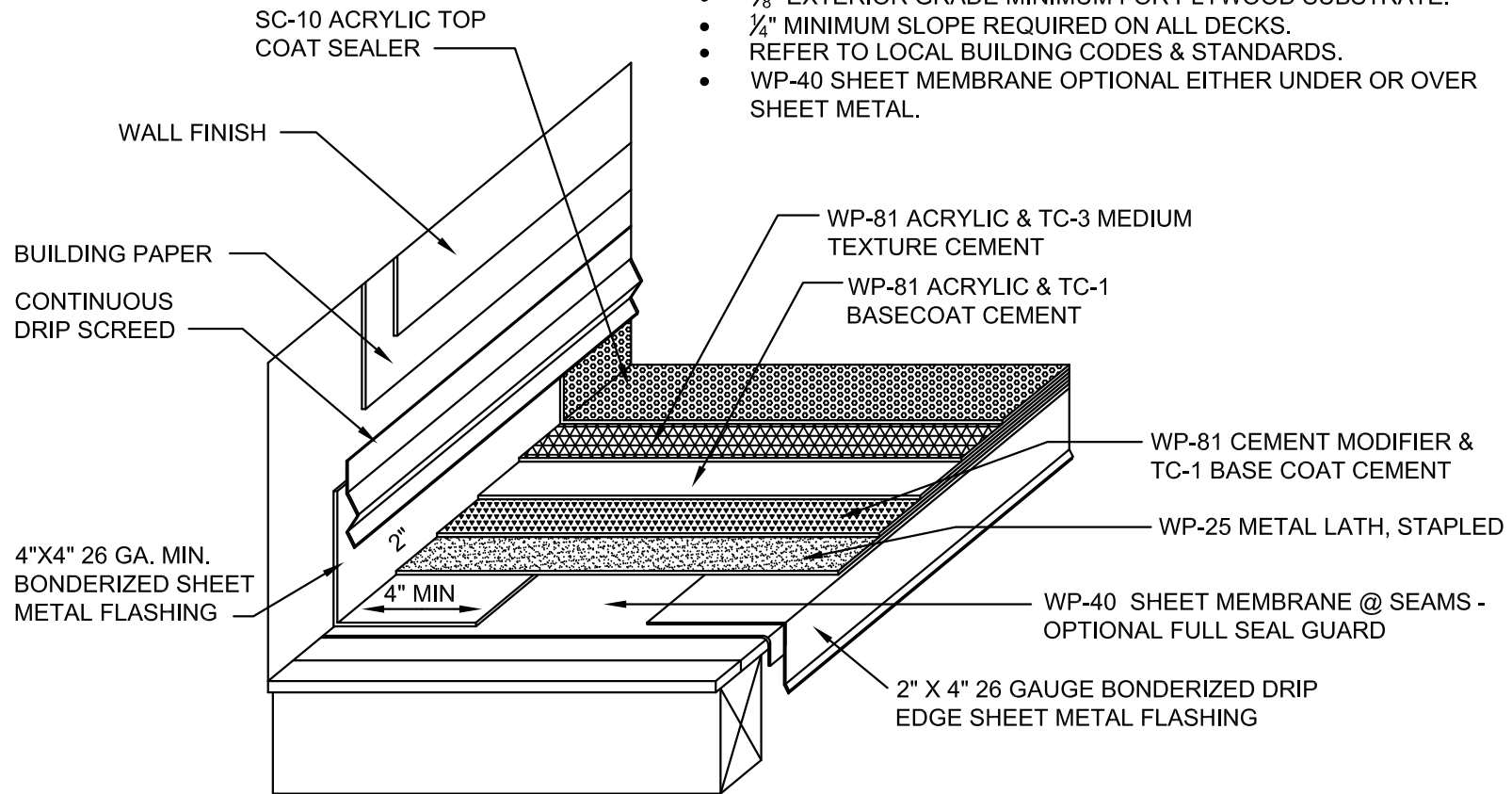

westcoat

800-250-4519
770 GATEWAY CENTER DRIVE

www.westcoat.com
SAN DIEGO, CA. 92102